

RETAIL SPACE FOR LEASE

1412 KINGS HIGHWAY

BETWEEN E14TH & E15TH

MIDWOOD | BROOKLYN NY

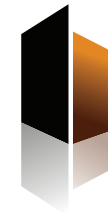

COMMERCIAL
ACQUISITIONS
REALTY SERVICES

5,291 SF
AVAILABLE FOR LEASE



COMMERCIAL ACQUISITIONS REALTY SERVICES
AVAILABLE FOR LEASE
718.517.8700 DENIS ABAYEV EXT 801
COMMERCIALACQ.COM Denis@CommercialACQ.com

COMMERCIAL ACQUISITIONS REALTY SERVICES
AVAILABLE FOR LEASE
718.517.8700 COMMERCIALACQ.COM
DENIS ABAYEV EXT 801 Denis@CommercialACQ.com

Fabco Shoes
FLAGSHIP OPPORTUNITY FOR LEASE - NEW CONSTRUCTION
62 FT. OF FRONTAGE • 6,000 SF GROUND FLOOR • SELLING 2ND FLOOR & BUILT TO SUIT • CALL OR EMAIL... 732.965.8913 • MAXW@FABSHOES.COM

COMMERCIAL ACQUISITIONS

SPACE DETAILS

LOCATION

Kings Highway Between
E14th & E15th Street

NEIGHBORHOOD

Homecrest/Midwood

SIZE

Ground Floor	2000 SF
Lower Level	2000 SF
Upper Levels	1291 SF

PRICE

Upon Request

FRONTAGE

21 FT

POSSESSION

Immediate

NEIGHBORS

Starbucks, Marshalls,
Target, Gamestop,
Chase, Citibank, Duane
Read, Chipotle, Taco
Bell, Subway & more

COMMENTS

- Major Branding Opportunity
- Over 5,000 SF on 3 levels plus a full basement
- 20FT Ceilings on the ground floor
- Ideal for all retail and specialty uses

TRANSPORTATION

Ridership
- 5,895,421

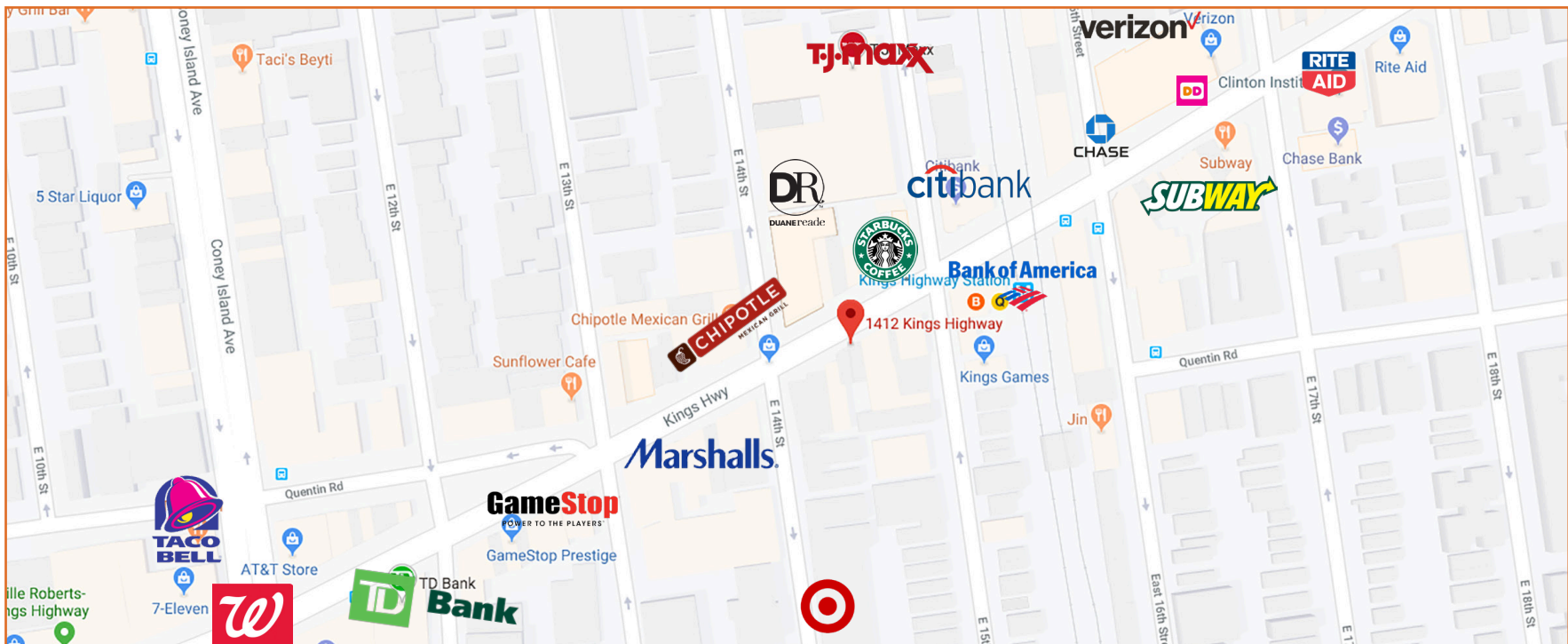

FLOOR PLANS

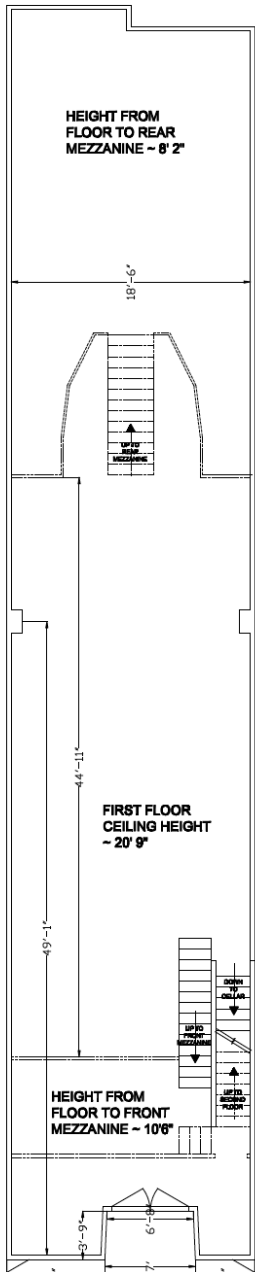

GROUND FL

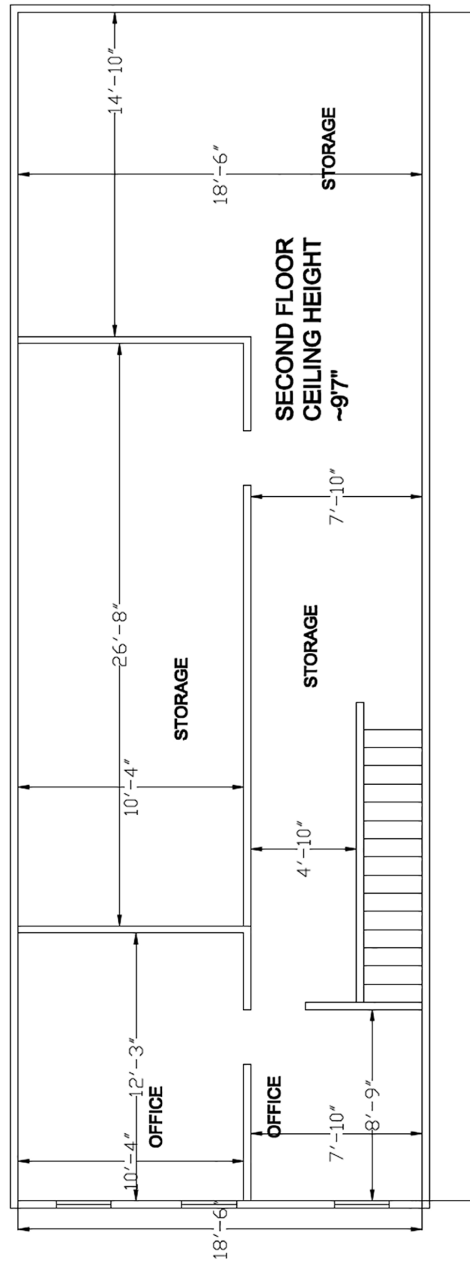

SECOND FL

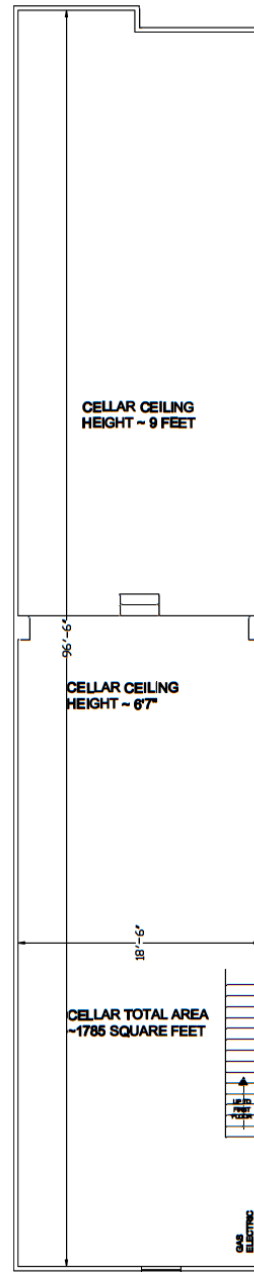

CELLAR

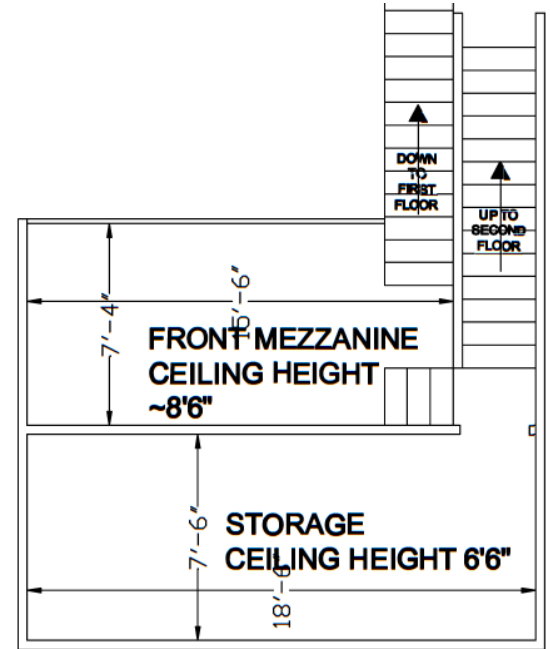

FRONT MEZZANINE

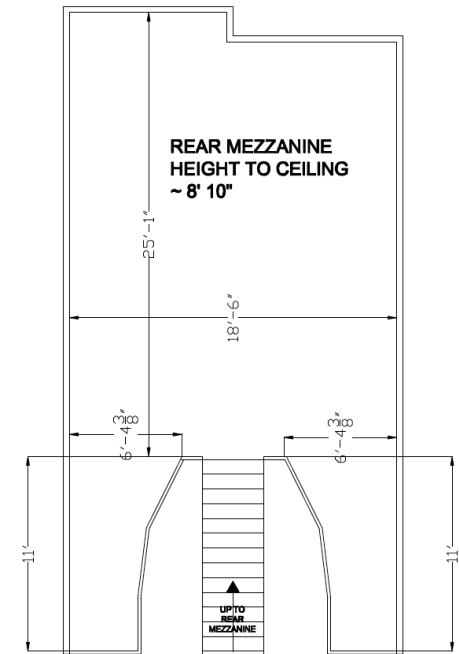

REAR MEZZANINE



**FOR MORE INFORMATION,
CONTACT EXCLUSIVE BROKER**

DENIS ABAYEV

Denis@commercialacq.com

718.954.1363

MORE INFORMATION ON THIS PROPERTY AND MORE PLEASE CALL OUR OFFICE:

718.517.8700



**COMMERCIAL
ACQUISITIONS**
REALTY SERVICES

2500 Coney Island Ave.
2nd Floor
Brooklyn NY, 11223
CommercialACQ.Com

Commercial Acquisitions Inc. has made every effort to obtain the information regarding these listings from sources deemed reliable. However, we cannot warrant the complete accuracy thereof subject to errors, omissions, change of price, rental or other conditions, prior sale, lease or financing, or withdrawal without notice. We recommend to the buyer that any information, which is of special interest, should be obtained through independent verification. ALL MEASUREMENTS MAY BE APPROXIMATE.