

280 Bartley Wood

HOOK RG27 9UP



TO LET / MAY SELL

Life's a doddle. 😊

Bartley Wood is an established business park in the desirable location of Hook, and is home to a host of major occupiers. 63,635 sq ft of high quality office space over three floors is now available at 280 Bartley Wood. The property lies just a short stroll from the village centre, as well as Hook station with its mainline connections to Basingstoke, Woking, Clapham Junction and London Waterloo.

Hook sits at the heart of the Blackwater Valley, enjoying a peaceful village atmosphere, favouring friendly village pubs and restaurants, coupled with a Tesco and a selection of local retail outlets. And yet, Basingstoke is right on the doorstep, plus other vibrant destinations such as Reading and Guildford are also nearby. Truly the best of both worlds!



The building.

Accommodation

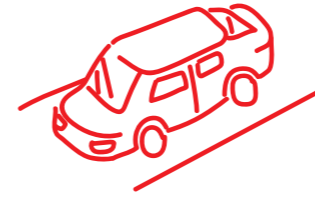

343 car spaces
- 1:186 sq ft



Shower facilities

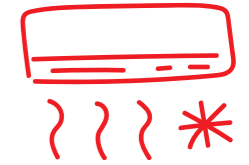

Air conditioning

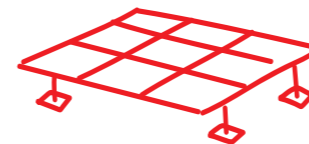

Accessible raised floors

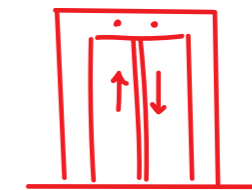

Passenger lifts

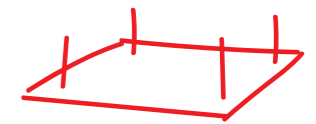

Suspended ceilings

Floor	sq ft	sq m
Third (storage)	2,211	205.4
Second	20,754	1,928.1
First	19,692	1,829.5
Ground	20,978	1,948.9
Total	63,635	5,911.9

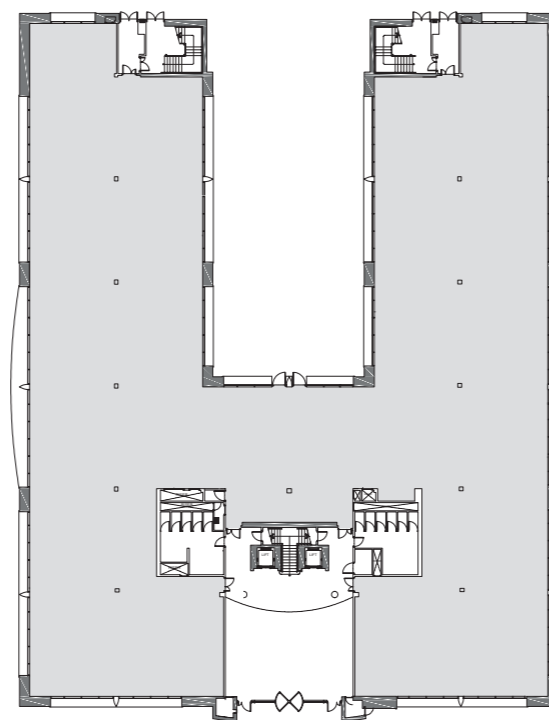

Ground floor

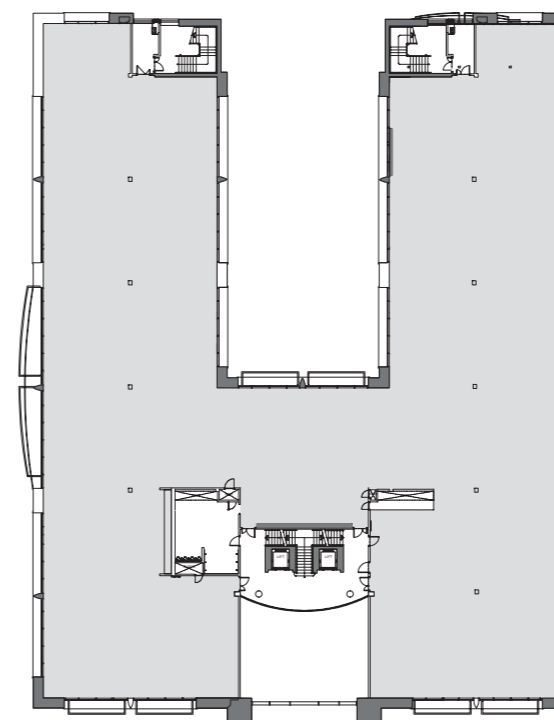

First floor

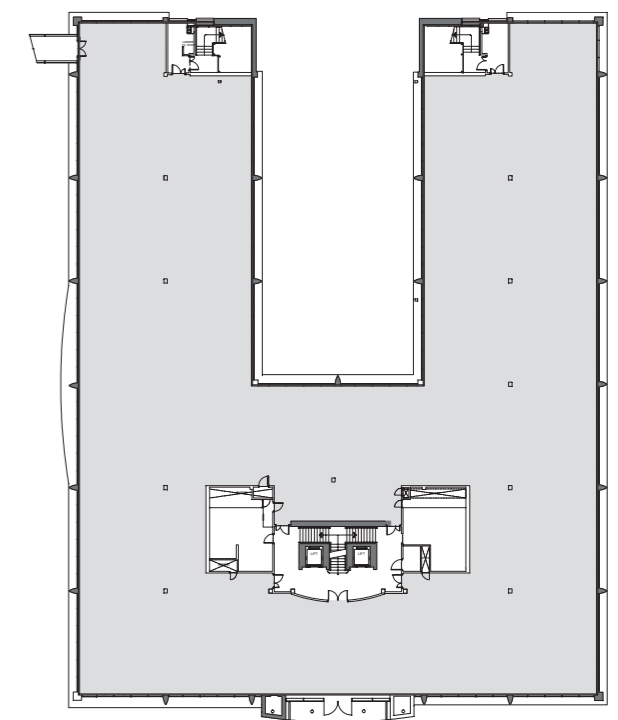

Second floor

Not to scale. For indicative purposes only.

Location.

hook, hampshire

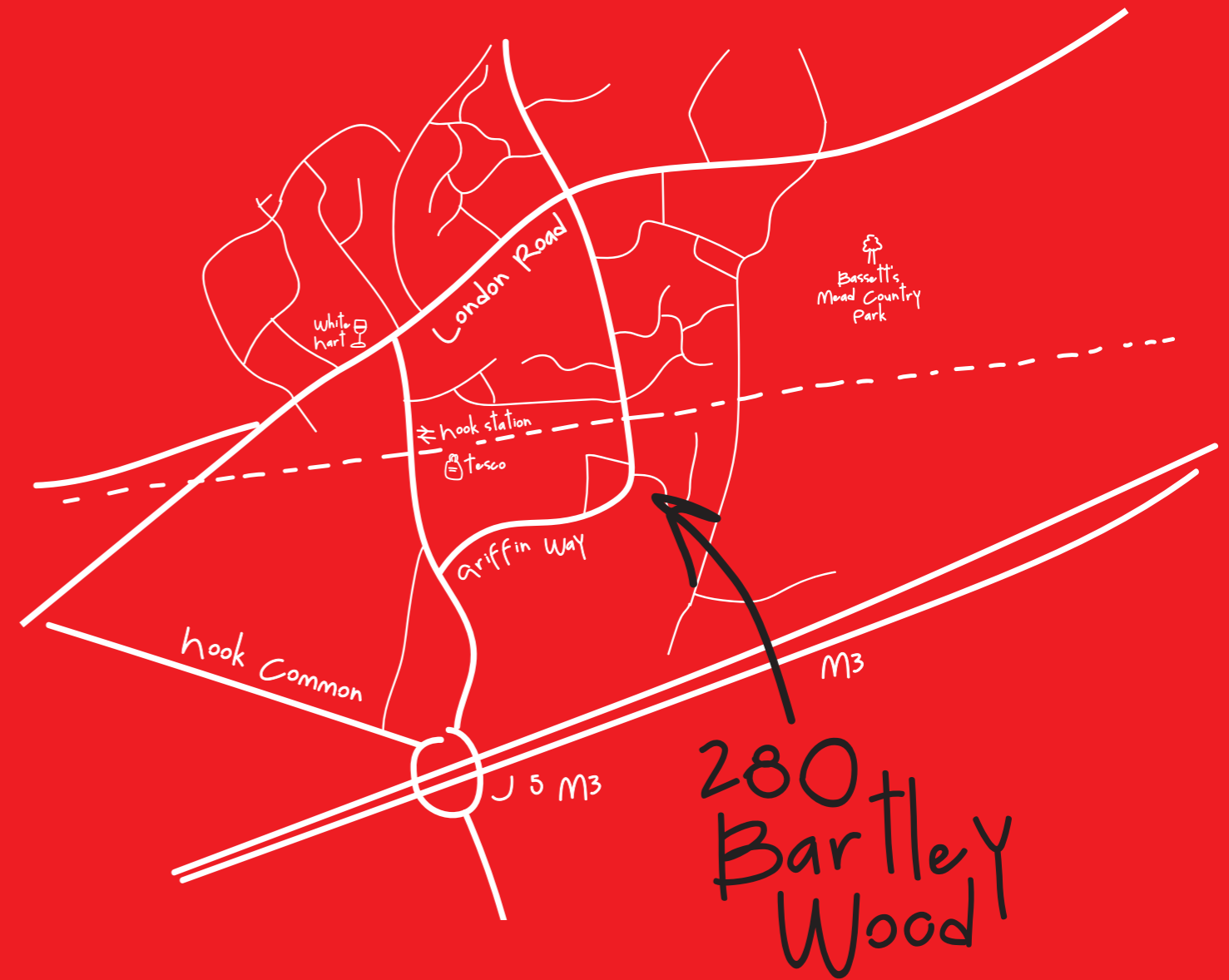

Regularly featured as one of the best places to live in the UK, it's hardly a surprise that Hook is also a superb place to work. Combine village life with great amenities - including hundreds of acres of natural countryside on your doorstep, perfect for woodland walks or runs - and you'll start to understand the appeal of 280 Bartley Wood...

By train...

Basingstoke	8 mins
Farnborough	14 mins
Woking	27 mins
Weybridge	34 mins
Clapham Junction	53 mins
London Waterloo	58 mins

By car...

J5 M3	0.9 miles
Tylney Hall Spa Hotel	4 miles
Four Seasons Spa Hotel	6 miles
Basingstoke	7 miles
Reading	14 miles
J12 M25	21 miles

On foot...

Hook station	14 mins
Tesco superstore	14 mins
The Raven pub & hotel	14 mins
Hook centre	15 mins
White Hart Hotel	15 mins
Old White Hart	16 mins



An unrivalled combination of

- ① village life,
- ② extensive amenities,
- ③ excellent communications.

Life's a doddle. 😊



James Shillabeer

07824 663 594
jameshillabeer@brayfoxsmith.com

Richard Harding

07730 817 019
richardharding@brayfoxsmith.com



Simon Fitch

07917 531 707
simon.fitch@hurstwarne.co.uk

Peter Richards

07803 078 011
peter.richards@hurstwarne.co.uk

280bartleywood.co.uk

Bray Fox Smith for themselves and for the vendors or lessors of this property whose agents they are, give notice that:- a. the particulars are set out as a general outline only for guidance and do not constitute, nor constitute part of, an offer or contract; b. all descriptions, dimensions, references to condition and necessary permissions for use and occupation, and other details are believed to be correct, but any intending purchasers, tenants or third parties should not rely on them as statements or representations of fact but satisfy themselves that they are correct by inspection or otherwise; c. no person in the employment of Bray Fox Smith has any authority to make or give any representation or warranty whatever in relation to the property; d. Any images maybe computer generated. Any photographs show only parts of the property as they appeared at the time they were taken. Designed and produced by The Looking Glass Design www.tlgd.co.uk. January 2020.