

1 PIPE GUARD DETAIL
NONE

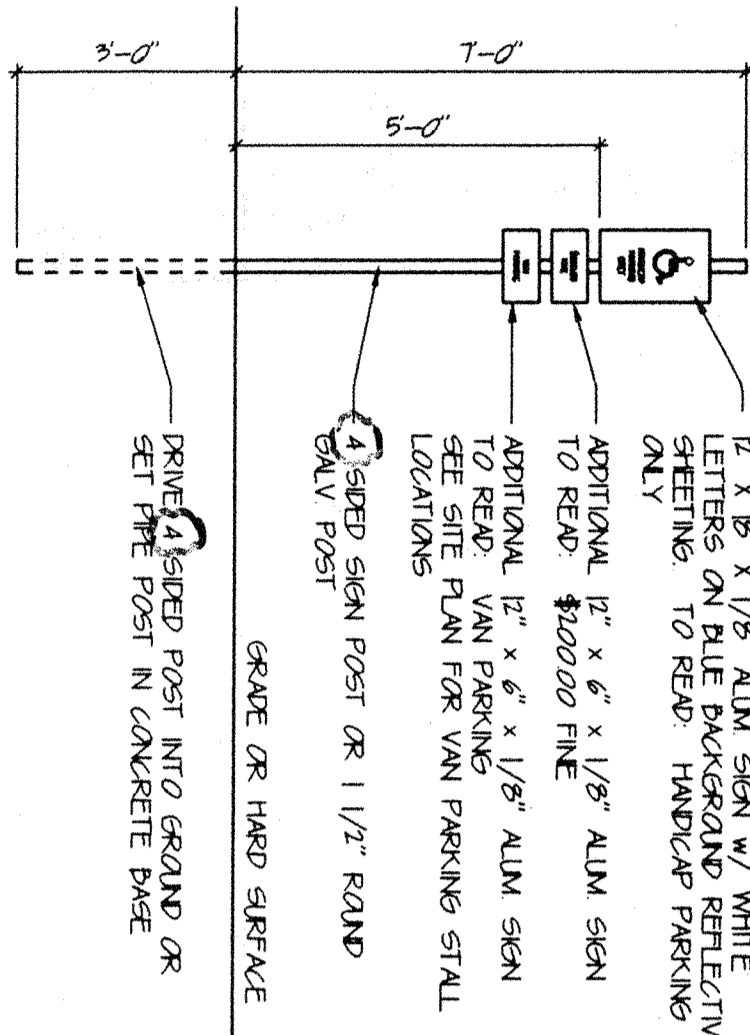

2 HDP PARKING SIGN
NONE

3 NOT USED
NONE

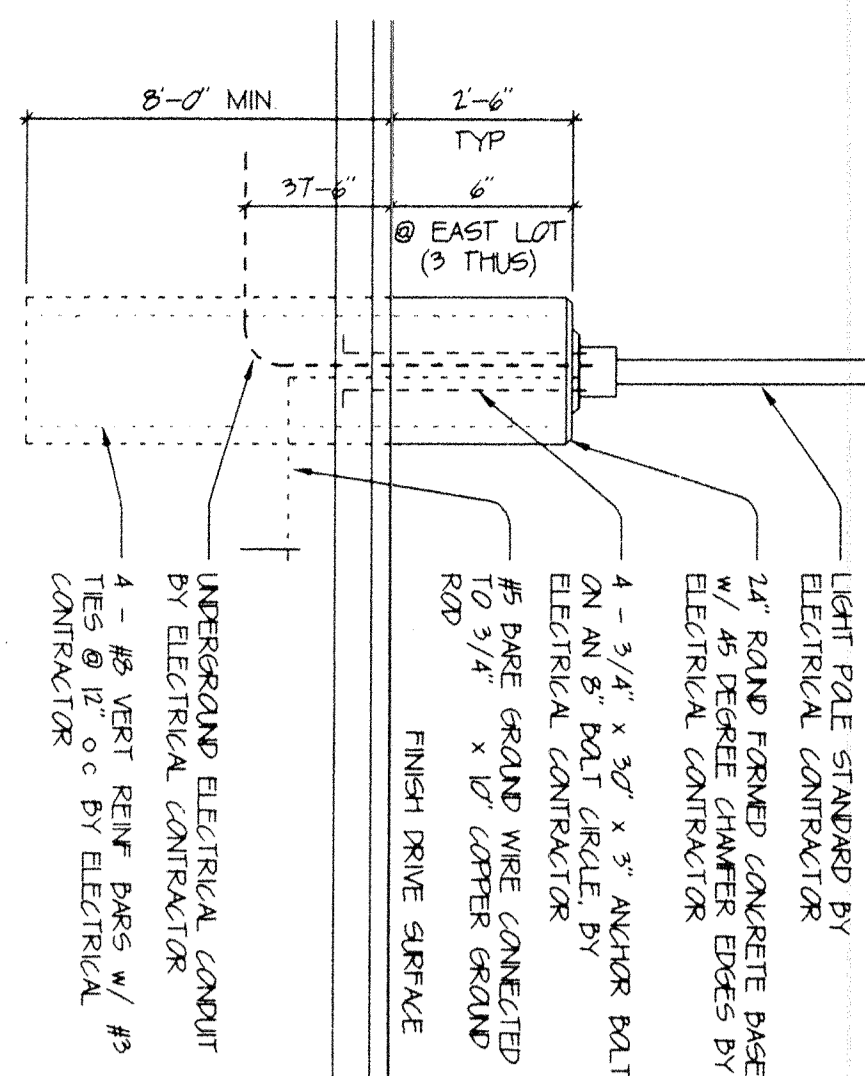

4 LIGHT POLE BASE
NONE

5 NOT USED
NONE

6 NOT USED
NONE

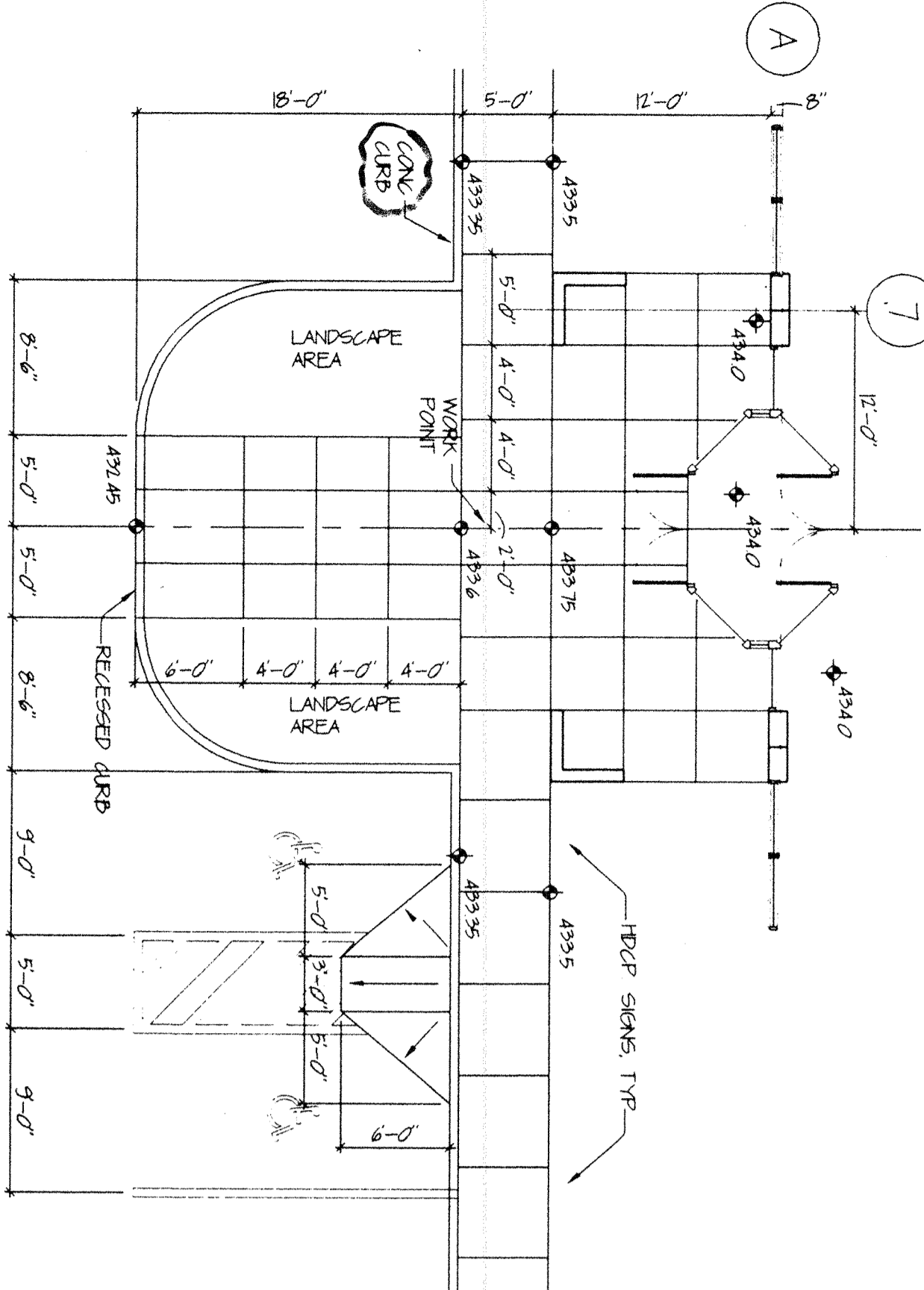

7 MAIN ENTRY AREA
1/8\"/>

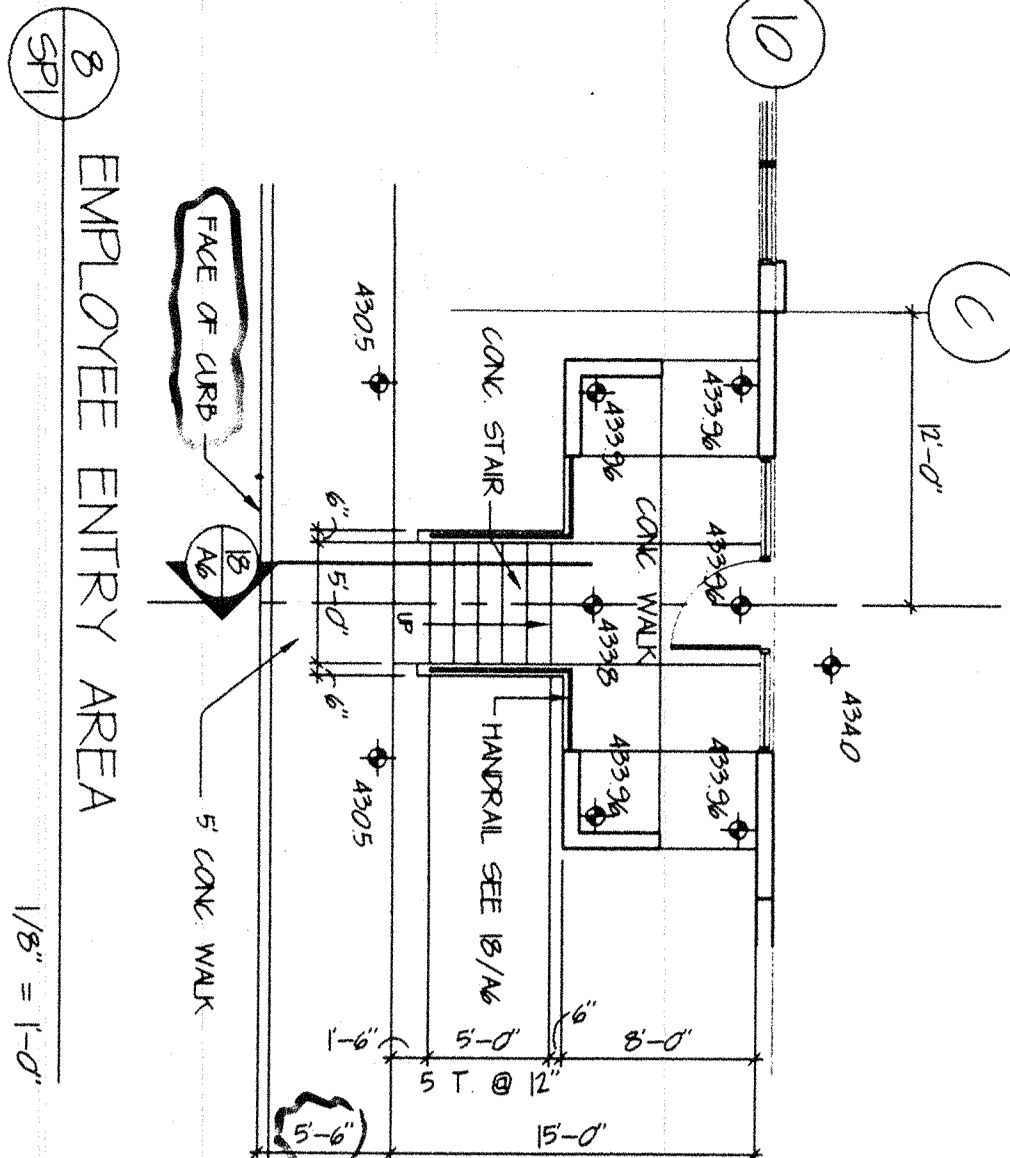

8 EMPLOYEE ENTRY AREA
1/8\"/>

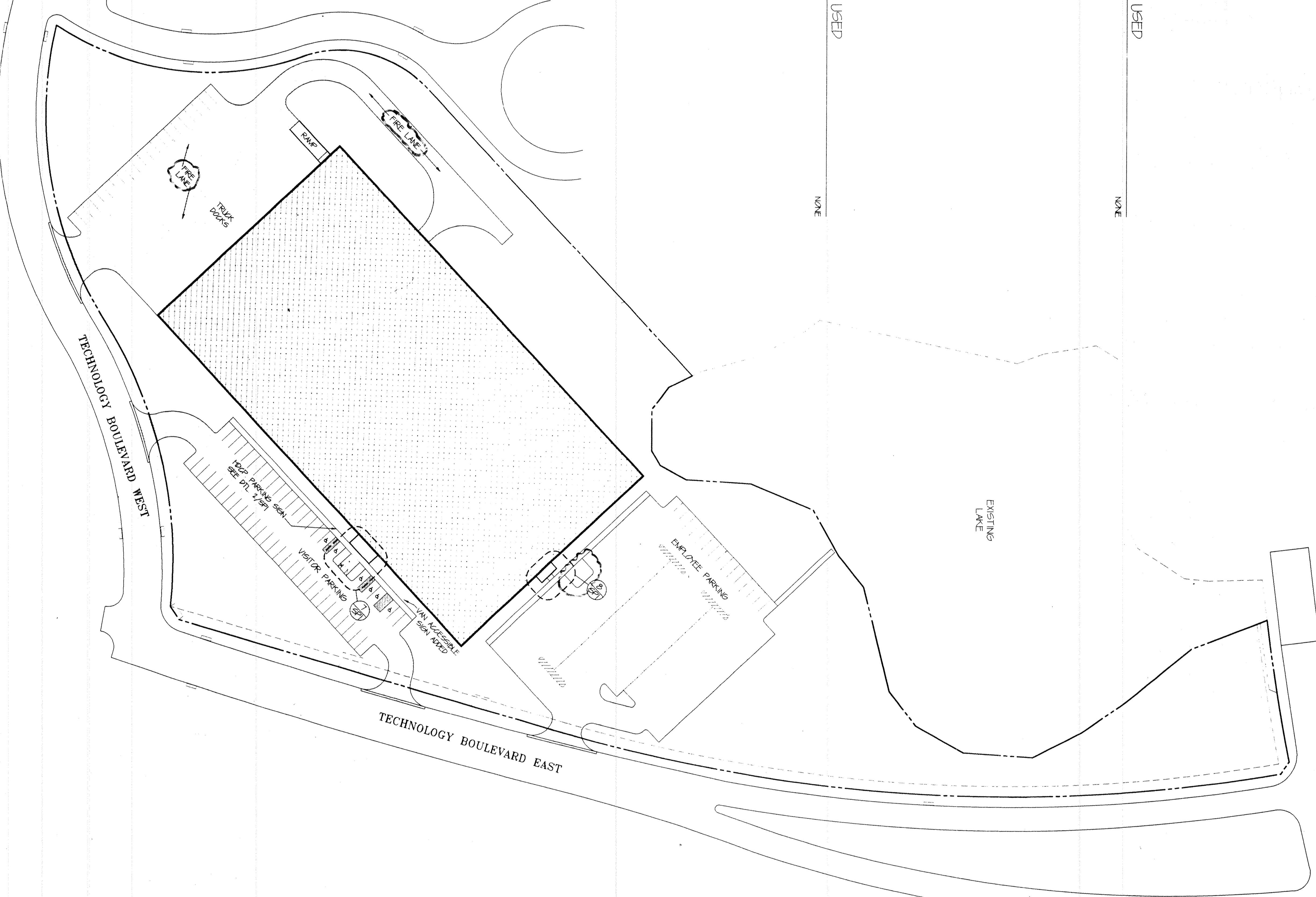

9 SITE PLAN
1\"/>

CODE ANALYSIS

PROJECT CODE ANALYSIS
1988 EDITION, UNIFORM BUILDING CODE

BUILDING AREA	21,888 SQ FT
OFFICE	1,980 SQ FT
PRODUCTION WAREHOUSE	46,980 SQ FT
WAREHOUSE	46,980 SQ FT
TOTAL AREA	103,848 SQ FT

OCCUPANT LOADS:

OFFICE	21,888 SQ FT / 100 = 219 OCCUPANTS
PRODUCTION WAREHOUSE	1,980 SQ FT / 200 = 10 OCCUPANTS
WAREHOUSE	46,980 SQ FT / 500 = 94 OCCUPANTS
TOTAL OCCUPANT LOAD	= 498 OCCUPANTS

OCCUPANCY CLASSIFICATION:
ALL AREAS B2 OCCUPANCY, WITH LUNCHROOM CLASSIFIED AS B OCCUPANCY AS A MINOR ACCESSORY USE.

CONSTRUCTION TYPE TO BE IN, BASED ON UNLIMITED AREA CRITERIA AS FOLLOWS:
CONSTRUCTION TYPE:

- GROUP B OCCUPANCY
- ONE-STORY BUILDING
- SYSTEM THROUGHOUT
- 60 FEET OF SETBACK ALL SIDES

ALL ELEMENTS OF EXTERIOR WALLS AND INTERIOR WALLS AND PARTITIONS, AS WELL AS ROOF ELEMENTS TO BE OF NON-COMBUSTIBLE CONSTRUCTION.

EXISTING:

OFFICE AREA

- TWO EXITS REQUIRED AND PROVIDED FOR 219 OCCUPANTS.
- ONE-HOUR RATED CORRIDOR PROVIDED THROUGH OFFICE AREA CONNECTED TO PRODUCTION WAREHOUSE.
- APPROXIMATE MAXIMUM TRAVEL DISTANCE EQUALS 150 FEET; 200 FEET ALLOWED.
- TWO EXITS REQUIRED AND PROVIDED THROUGH LUNCHROOM FOR 92 OCCUPANTS (17/15 SQ FT).

PRODUCTION AREA

- TWO EXITS PROVIDED FOR 165 OCCUPANTS.
- APPROXIMATE MAXIMUM TRAVEL DISTANCE EQUALS 160 FEET; 200 FEET ALLOWED.

WAREHOUSE AREA (INCLUDING OFFICE):

- FIVE EXITS PROVIDED FOR 114 OCCUPANTS.
- APPROXIMATE MAXIMUM TRAVEL DISTANCE EQUALS 180 FEET; 200 FEET ALLOWED.

SMOKE AND HEAT VENTING:

WAREHOUSE CRITERIA:

- STORAGE TO 20 FEET MAXIMUM HEIGHT PER CLASSIFIED AS HIGH OF THE UNIFORM FIRE CODE.
- STORAGE ITEMS CATEGORIZED AS CLASS 3 OPEN WAREHOUSE AREA EQUALS 46,980 SQ FT.

ROOF VENTS / CURTAIN BOARDS:

- 4' x 8' AUTOMATICALLY OPERATED VENTS PROVIDED AT 1:100 RATIO TO MINIMIZE RISE.
- NATURAL EXHAUST CURTAIN BOARDS EXTENDING 6' DOWN FROM METAL ROOF DECK TO BE PROVIDED FORMING MAXIMUM PLAIN AREAS OF 10,000 SQ FT WALLS.
- MAXIMUM PLAIN AREA SHALL BE 100 FEET ON CENTER, MAXIMUM DISTANCE FROM WALL OR CURTAIN BOARD EQUALS 60 FEET.

GENERAL NOTES

- FOR SITE LAYOUT DIMENSIONS, GRADING AND UTILITIES, SEE CIVIL DRAWINGS.
- FOR ON-SITE LIGHT POLE LOCATIONS, SEE SITE UTILITY PLAN.
- ALL SURFACE PAVING TO BE CONCRETE. SEE CIVIL DRAWINGS FOR STANDARD AND HEAVY DUTY PAVEMENT LOCATIONS AND DETAILS.
- SHADED AREAS OF PAVEMENT DENOTE FIRE LAKES (TYPICAL).