

**SITE PLAN DIAGRAM**

SCALE: 1" = 40'-0"

ZONL. R8, C2.3

LOT AREA: 16,470 SF AS PER 23-32  
 LOT COVERAGE: 72.6% AS PER 23-145  
 FAR: 3.0 AS PER 23-145  
 FRONT YARD: 0'-0" AS PER 23-43  
 SIDE YARDS: 0'-0" AS PER 23-462 (C)  
 REAR YARD: 0'-0" AS PER 23-47

**LEGEND:**

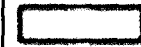
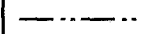
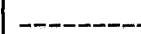
-  PROPOSED BUILDING
-  ZONING LOT LINE
-  SKY EXPOSURE PLANE

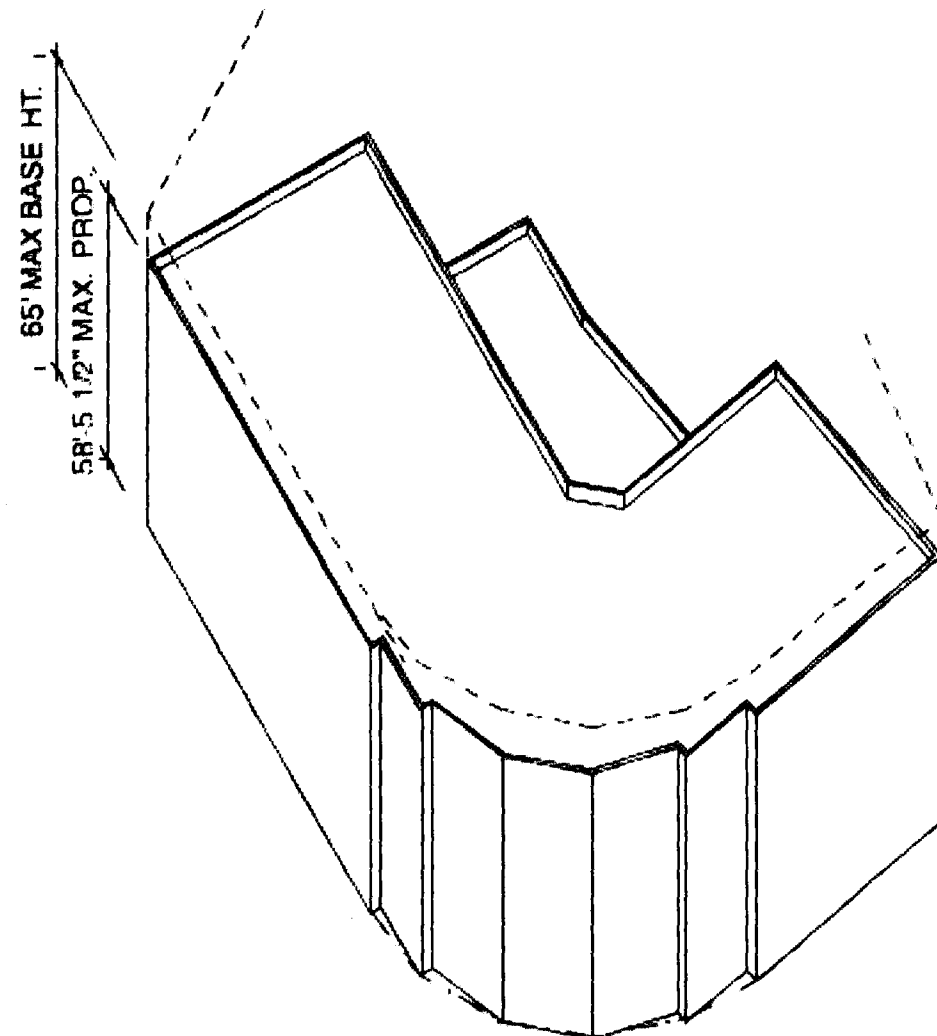
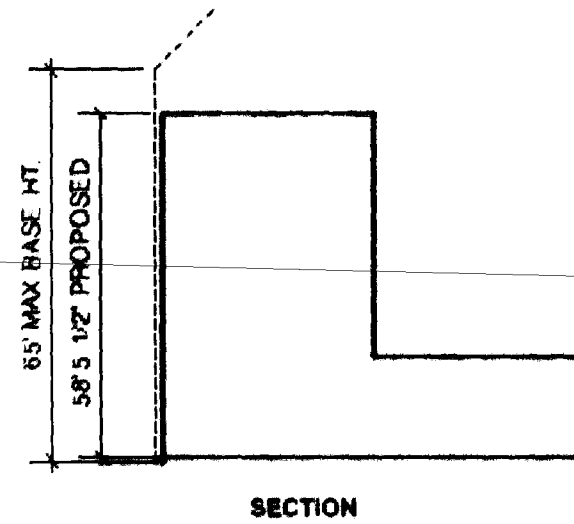
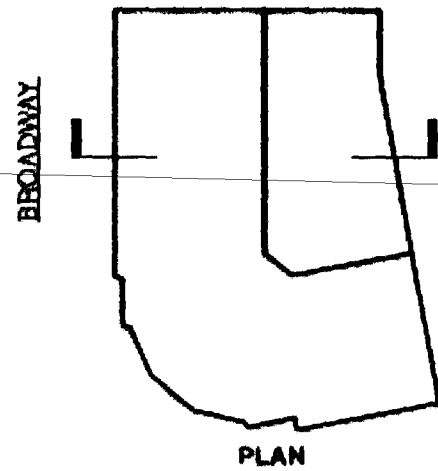
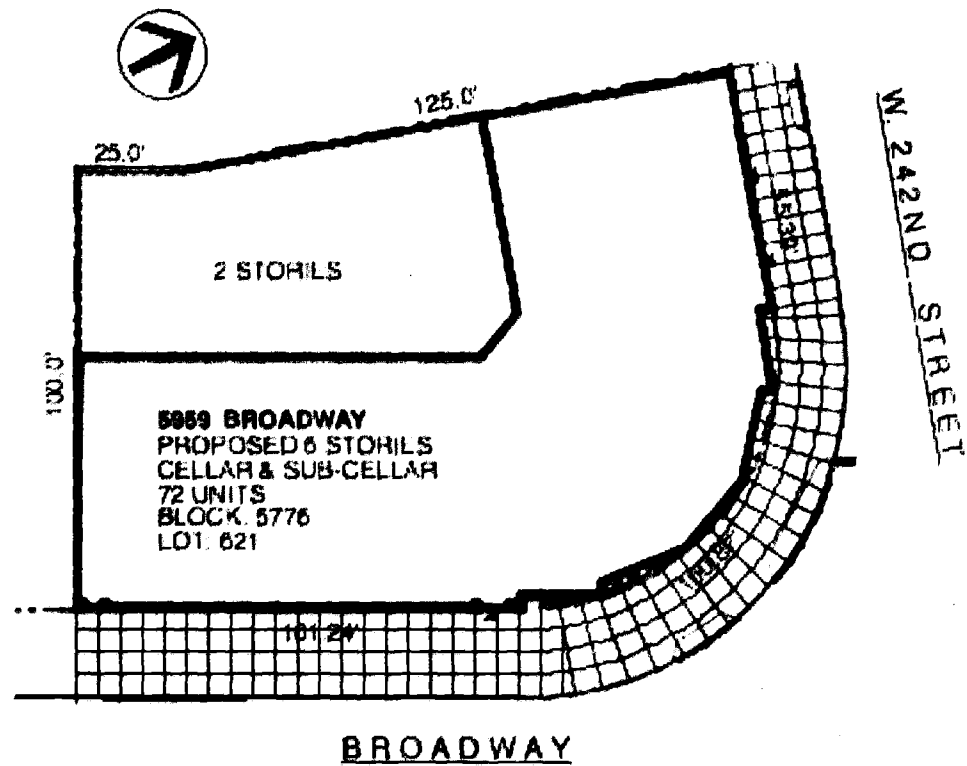

**ZD1 Zoning Diagram**  
 Must be typewritten.



Submitted to resolve objections stated in a notice of intent to revoke issued pursuant to rule 101-15.  Yes  No

**Location Information**

House No(s) 5959  
 Street Name BROADWAY  
 Borough BRONX  
 Block 5776  
 Lot 621  
 BIN 2124471

Falsification of any statement is a misdemeanor and is punishable by a fine or imprisonment, or both. It is unlawful to give to a city employee, or for a city employee to accept, any benefit, monetary or otherwise, either as a gratuity for properly performing the job or in exchange for special consideration. Violation is punishable by imprisonment or fine or both. I understand that if I am found after hearing to have knowingly or negligently falsified or allowed to be falsified any certificate, form, signed statement, application, report or certification of the correction of a violation required under the provisions of this code or of a rule of any agency, I may be barred from filing further applications or documents with the Department.

Name (please print)

MOHAMMAD BADALY

Signature

Date

07/24/14

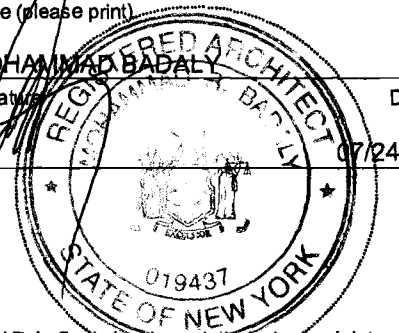

P.E. / R.A. Seal (apply seal, then sign and date over seal)

**Internal Use Only**

BIS Doc #

PLAN EXAMINER SIGN AND DATE

