

CONCEPTUAL DRAWING:~

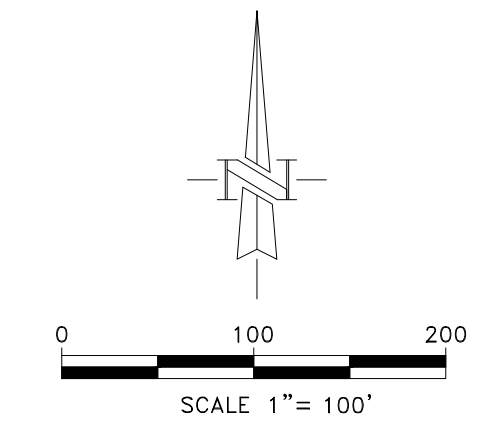

DESCRIPTION:
 LAND SITUATED IN THE TOWNSHIP OF ORONOKO, COUNTY OF BERRIEN,
 STATE OF MICHIGAN, AND IS DESCRIBED AS FOLLOWS:
 THAT PART OF THE SOUTHWEST QUARTER OF THE SOUTHEAST QUARTER
 OF THE NORTHWEST QUARTER AND THAT PART OF THE EAST 40 ACRES
 OF THE NORTHWEST QUARTER LYING SOUTH OF THE HIGHWAY KNOWN AS
 SNOW ROAD, ALL IN SECTION 30, TOWNSHIP 6 SOUTH, RANGE 18 WEST,
 ORONOKO TOWNSHIP, BERRIEN COUNTY, MICHIGAN.



GENERAL NOTES:

- 1) THE SUBJECT PROPERTY CONTAINS 36.5 ACRES, MORE OR LESS, SUBJECT TO SURVEY. A BOUNDARY SURVEY WAS NOT PERFORMED FOR THIS CONCEPTUAL.
- 2) THE SUBJECT ADDRESS IS 438 E. SNOW ROAD, BARODA, MI 49101
- 3) THE SUBJECT PARCEL ID# IS: 11-15-0030-0005-00-6.
- 4) THE SUBJECT IS PROPOSED TO BE SERVICED BY INDIVIDUAL WELLS AND SEPTIC SYSTEMS.
- 5) THE ORDINANCE ALLOWS PUBLIC OR PRIVATE ROADWAYS 66' WIDE TO BE DESIGNED TO BERRIEN COUNTY ROAD SPECIFICATIONS BY A LICENSED ENGINEER. THE PROPOSED ROADWAY IS 2,805 LINEAL FEET.
- 6) A TITLE COMMITMENT WILL NEED TO BE PROVIDED FOR EASEMENTS OF RECORD AND MAY AFFECT THE NUMBER AND LOCATION OF LOTS SHOWN.
- 7) THE PROPERTY IS ZONED AGRICULTURAL/RESIDENTIAL WITH FOLLOWING REQUIREMENTS:
 MINIMUM SIZE PARCELS: 1 ACRE
 MINIMUM FRONTAGE: 150'
 FRONT SETBACKS: 40'
 SIDE SETBACKS: 10'
 REAR SETBACKS: 50'

C. 1/4 CORNER
 SEC. 30, T6S-R18W