

For Sale

Car Wash Express
1629 Western Center Rd,
DFW, TX

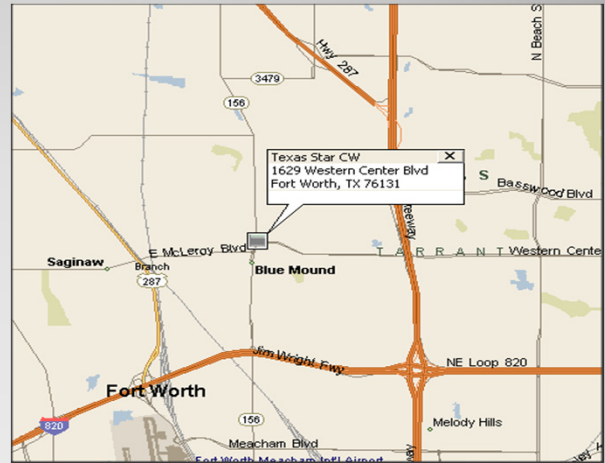

Exclusively listed by: Roger A. Pencek - BROKER

- Express Car Wash w land (.83 acre) Lic # 470334
- Hanna Equip 107' conveyor w 17 vacs
- Built in 2017 NEW, Absentee Owners
- **DFW huge Traffic count and high memberships**
- ALL buyers sign NDA's and Proof Of Funds (POF)



Branch Offices** USA

\$2.8M

Contact: Roger A. Pencek - Broker



Car Wash Brokers, Inc., aka Acquisitions Businesses & Investments LLC
11408 N. Blackheath Rd., Scottsdale, AZ 85254

Tel: 602-787-1100 Fax: 480-483-1116 Email: roger@carwashbrokers.com

Visit us online at www.carwashbrokers.com

Roger A. Pencak
Designated Broker
President, M.B.A.

Web Page
www.carwashbrokers.com



Branch Offices ** USA

Car Wash Brokers, Inc.

Corporate Office
11408 N Blackheath Rd.,
Scottsdale, AZ 85254



Corporation Office

Office: (602) 787-1100
Fax: (480) 483-1116
Mobile: (602) 770-4040
roger@carwashbrokers.com



CONFIDENTIAL BUSINESS INFORMATION

TYPE OF BUSINESS: Express Car Wash

Listing Agent: RAP
Bus. Name: Texas Star Express
Address: 1629 Western Center Rd,
City: DFW, TX State: TX Zip: 76131
Yrs In Operation: 1998 By Seller: present
Reason for Sale: Other Interest

FINANCIAL DATA

Purchase Price: 2.8M
Down Payment: CASH
Balance: _____
OWNERS TERMS:
Terms/Yrs: 0 Int Rate: 0%
Monthly Payment: \$0.00
Other: _____

LEASE INFORMATION

Bldg Size: 3,028+- sq. ft. Lot Size: 0.93+- Mo Rent: N/A
Major Cross St: Western Center Rd and Blue Mound
Lease Period: _____ Options: _____ Deposits: _____

REAL ESTATE (if applicable)

Sale Price: Included
Int % _____ # Years _____
SELLERS ESTIMATE OF MARKET VALUE
Equip/Fbx: \$600K
Work in Proceess: \$0
Inventory: \$0
Tenant Imp.: \$0
Cov. Not to Compete: \$0
Bus. Name: \$0
Goodwill: \$
Contracts: \$0
Franchise/License: \$0
Other: (Land) \$1M
Other: (Bldg.) \$1.2M
TOTAL: \$2.8M

GENERAL INFORMATION

Days/hrs. open: 7
Seller's Duties/hrs. worked: 0
Family/Partners work hours: 0
Number of employees: 4 Full Time _____ PT _____
License Requirements: N/A
Type of Sale: _____ Stock X Asset _____
Seller Train Buyer @ N/C: Yes
How Long?: 2 weeks

COMMENTS: **100% CONFIDENTIAL ALL BUYERS MUST NDA AND POE**

Directions: _____
Absentee owner !!!
This Absentee Business opened 2017 and ready for turn key buyer.
ON SITE new owner can increase business substantially; 425 +- memberships
Parcel # 42163828 **ALL current employees experienced and can run the operation.**
Hanna TOTAL NEW track w Washafi Membership tracking system-GROWING neighborhood loyal base

BUSINESS FINANCIAL INFORMATION OF: 2019 2018

EST. Total Sales: **\$408K** \$550K
Cost of Goods: _____
Gross Profit: _____
Benefits & Income: _____

DISCLAIMER: The information contained herein is from the Broker's Agreement Questionnaire and/or Financial Information provided by the Seller. It has not been audited, nor investigated by Car Wash Brokers, Inc. (Broker) and is subject to prior sale. A prospective buyer is expected to fully investigate the business to his/her satisfaction before purchasing.

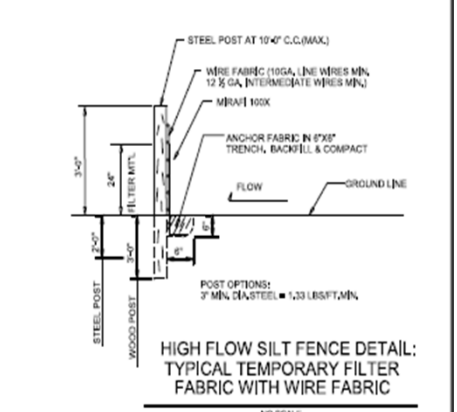
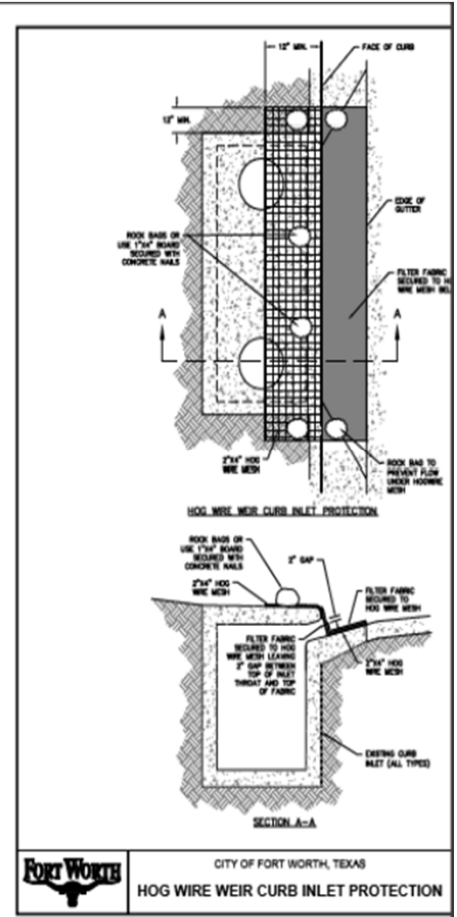
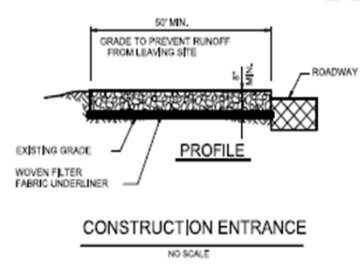
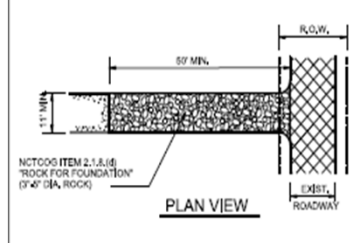
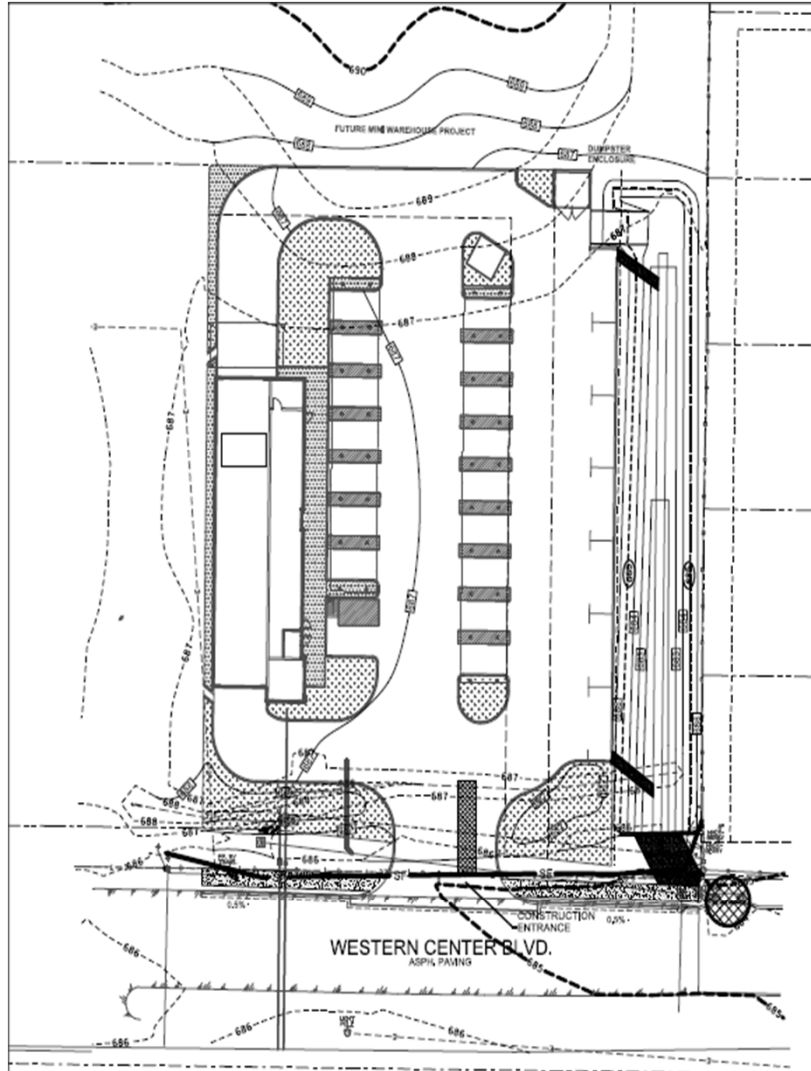

| | | | | | |
|----|---------------------------------|---------------------------|-----------------------------|--|-------------------|
| 1 | Equipment List | Texas Star Express | | | |
| 2 | Tunnel | | Back Room | | POS System |
| 3 | Correlator | Hanna | High Pressure | | Washify |
| 4 | Conveyor 107' | Hanna | Air Compressor | | Cashier |
| 5 | Wheel Blaster | Hanna | Chemical Board 2 | | Manager Station |
| 6 | Wrap Set | Hanna | Hanna DSI System | | |
| 7 | HCRP 28" | Hanna | Hydraulic Tank | | |
| 8 | HCRP 21" | Hanna | Hydraulic Tank | | |
| 9 | Wrap Set | Hanna | Sweet Water Raclaim Stystem | | |
| 10 | Mitter HSS-2 | Hanna | RO System | | |
| 11 | Mitter HFTM | Hanna | 3 pump on DSI System | | |
| 12 | CTA | Mr Foamer | MCC & Controller Laguna | | |
| 13 | CTA | Mr Foamer | | | |
| 14 | Flood Rinse | TSS | | | |
| 15 | Drying Aid | TSS | | | |
| 16 | Sealer Wax | TSS | | | |
| 17 | RO Rinse | TSS | | | |
| 18 | Pre Soak | Mr Foamer | | | |
| 19 | Lava Arch | | | | |
| 20 | Premium Wax Arch | | | | |
| 21 | Triple Shine | | | | |
| 22 | Exit Sign | | | | |
| 23 | Entrance Sign | | | | |
| 24 | Top Brush | | | | |
| 25 | | | | | |
| 26 | Vacuum | | | | |
| 27 | 16 Lanes Awning AutoVac | | | | |
| 28 | 2-25 hp Vac Motors and turbines | | | | |
| 29 | | | | | |
| 30 | | | | | |
| 31 | | | | | |

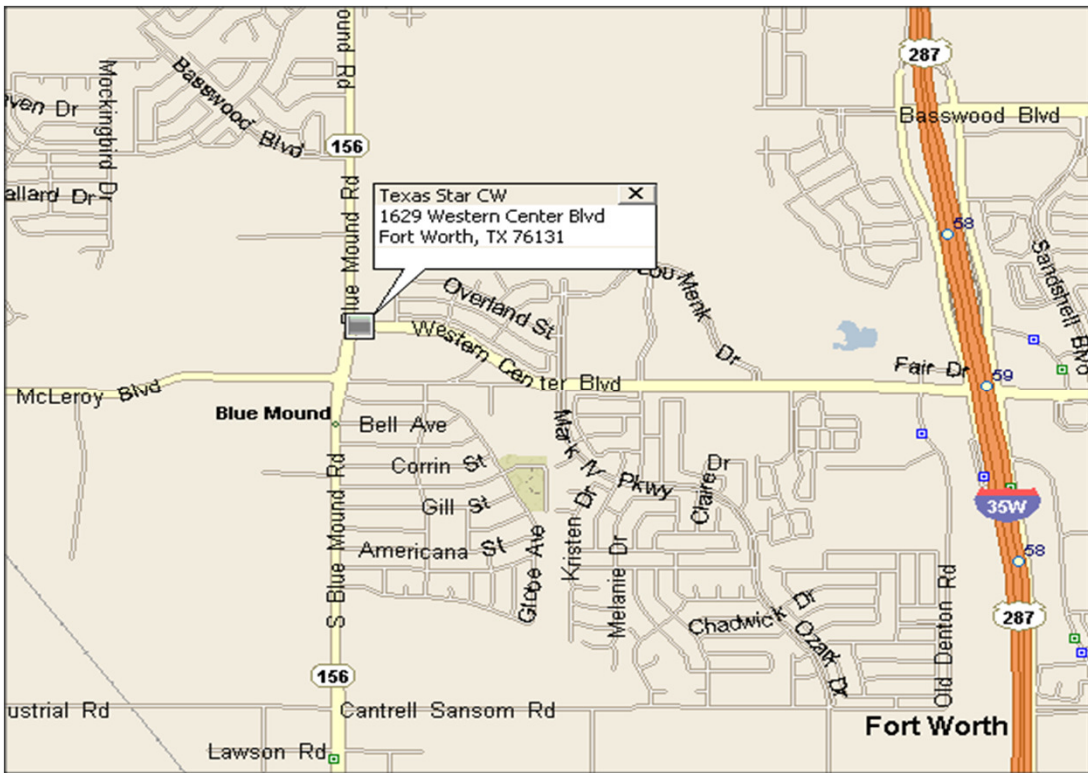
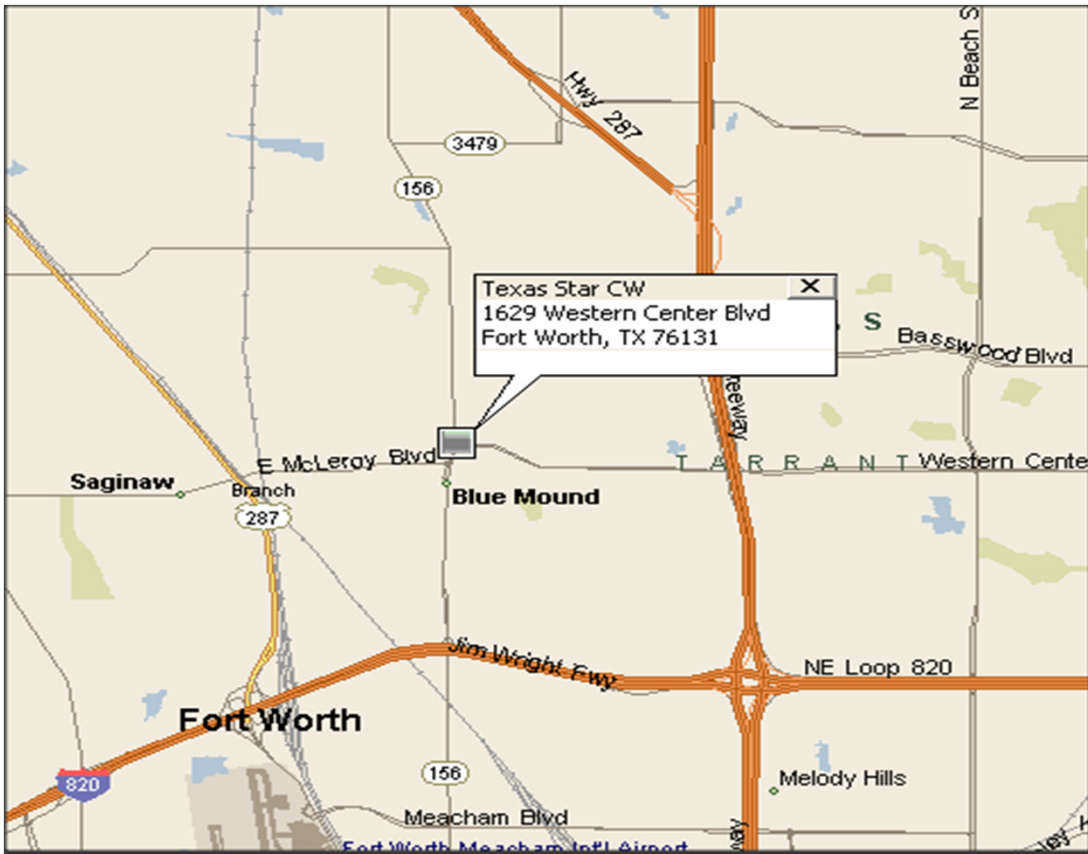

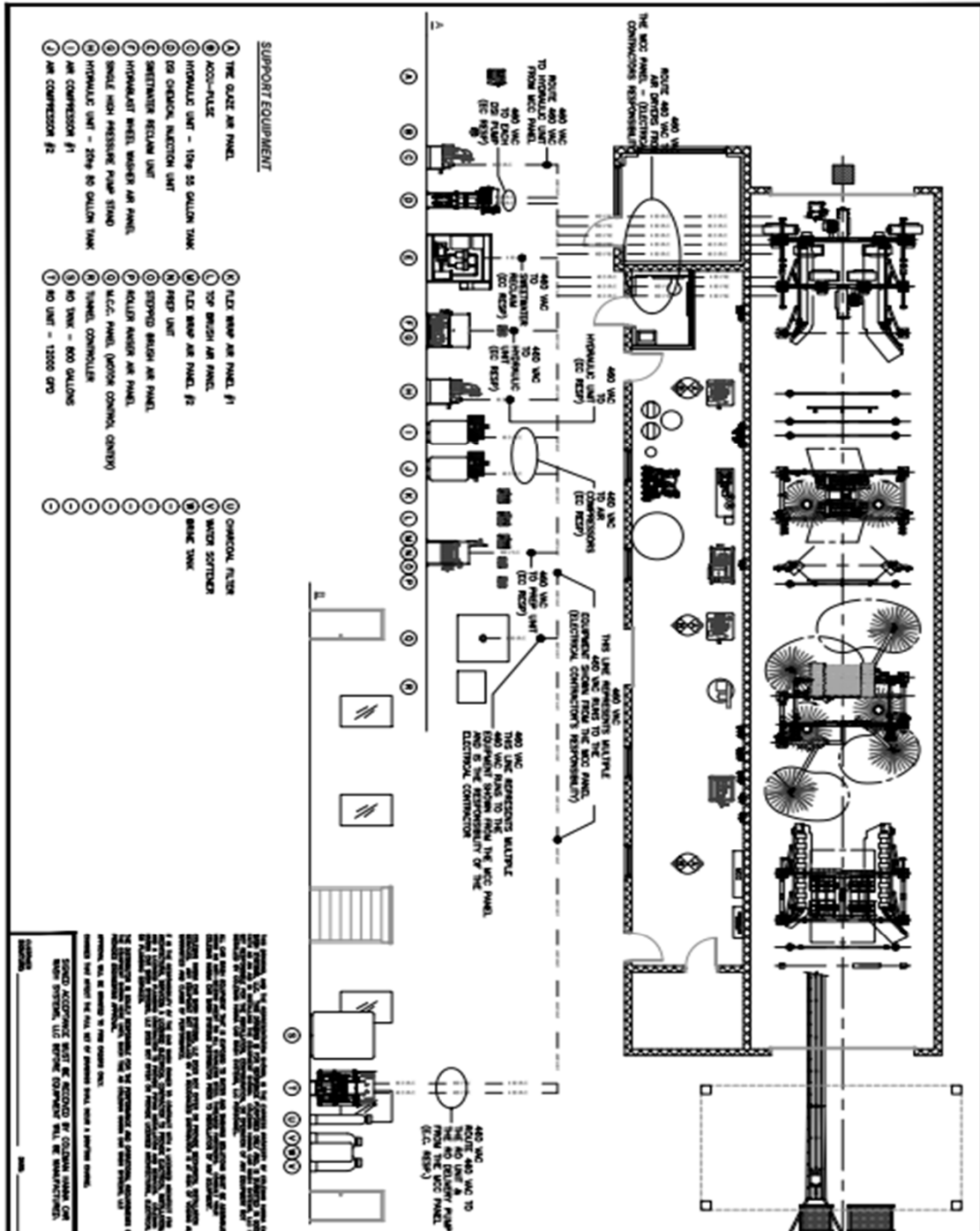

SUPPORT EQUIPMENT

- 1 THE GLAZZ AIR PANEL
- 2 ACQU-FILZ
- 3 HYDRAULIC UNIT - 100% 55 GALLON TANK
- 4 55 GALLON CHEMICAL INJECTION UNIT
- 5 SWEETENER RECUMIN UNIT
- 6 HYDRAULIC SHEET WINDER AIR PANEL
- 7 SINGLE HIGH PRESSURE PUMP STAND
- 8 HYDRAULIC UNIT - 200% 60 GALLON TANK
- 9 AIR COMPRESSOR #1
- 10 AIR COMPRESSOR #2
- 11 FLDX RAMP AIR PANEL #1
- 12 TOP BRUSH AIR PANEL
- 13 FLDX RAMP AIR PANEL #2
- 14 FLDX UNIT
- 15 SWEETNER BRUSH AIR PANEL
- 16 SOLDER ANCHOR AIR PANEL
- 17 MCC. PANEL (POWER CONTROL CENTER)
- 18 TUNNEL CONTROLLER
- 19 60 TANK - 600 GALLONS
- 20 60 UNIT - 12000 GPD
- 21 CHEMICAL FILTER
- 22 BRUSH SORTER
- 23 BRUSH TANK

THE DRAWING IS THE PROPERTY OF COLEMAN HANNA CAR WASH SYSTEMS, LLC. IT IS TO BE USED ONLY FOR THE PROJECT AND SITE SPECIFICALLY IDENTIFIED. IT IS NOT TO BE REPRODUCED, COPIED, OR TRANSMITTED IN ANY FORM OR BY ANY MEANS, ELECTRONIC OR MECHANICAL, INCLUDING PHOTOCOPYING, RECORDING, OR BY ANY INFORMATION STORAGE AND RETRIEVAL SYSTEM, WITHOUT THE WRITTEN PERMISSION OF COLEMAN HANNA CAR WASH SYSTEMS, LLC. ANY UNAUTHORIZED USE OF THIS DRAWING IS STRICTLY PROHIBITED. COLEMAN HANNA CAR WASH SYSTEMS, LLC SHALL BE RESPONSIBLE FOR THE ACCURACY OF THE INFORMATION AND DATA PROVIDED HEREON. THE USER OF THIS DRAWING SHALL BE RESPONSIBLE FOR OBTAINING ALL NECESSARY PERMITS AND APPROVALS FROM ALL APPLICABLE AGENCIES AND AUTHORITIES. THE USER SHALL BE RESPONSIBLE FOR OBTAINING ALL NECESSARY PERMITS AND APPROVALS FROM ALL APPLICABLE AGENCIES AND AUTHORITIES. THE USER SHALL BE RESPONSIBLE FOR OBTAINING ALL NECESSARY PERMITS AND APPROVALS FROM ALL APPLICABLE AGENCIES AND AUTHORITIES.

| | | | |
|---|------------------------|-------------------------|--------------------|
| COLEMAN HANNA CAR WASH SYSTEMS, LLC - AN OTHWELMAN CO. COMPANY 1300 W. BRIDGE ST. DALLAS, TX 75243 TEL: 972.442.2266 FAX: 972.442.2266 | | | |
| TEXAS EXPRESS CAR WASH 1300 W. BRIDGE ST. DALLAS, TX 75243 | | | |
| DATE: February 1, 2017 | DRAWN BY: J. H. HANNA | CHECKED BY: J. H. HANNA | PROJECT NO: 1300WB |
| SCALE: AS SHOWN | DATE: February 1, 2017 | FILE NO: 1300WB-01-000 | |

AN OTHWELMAN CO. COMPANY
1300 W. BRIDGE ST.
DALLAS, TX 75243
TEL: 972.442.2266 FAX: 972.442.2266

E/1

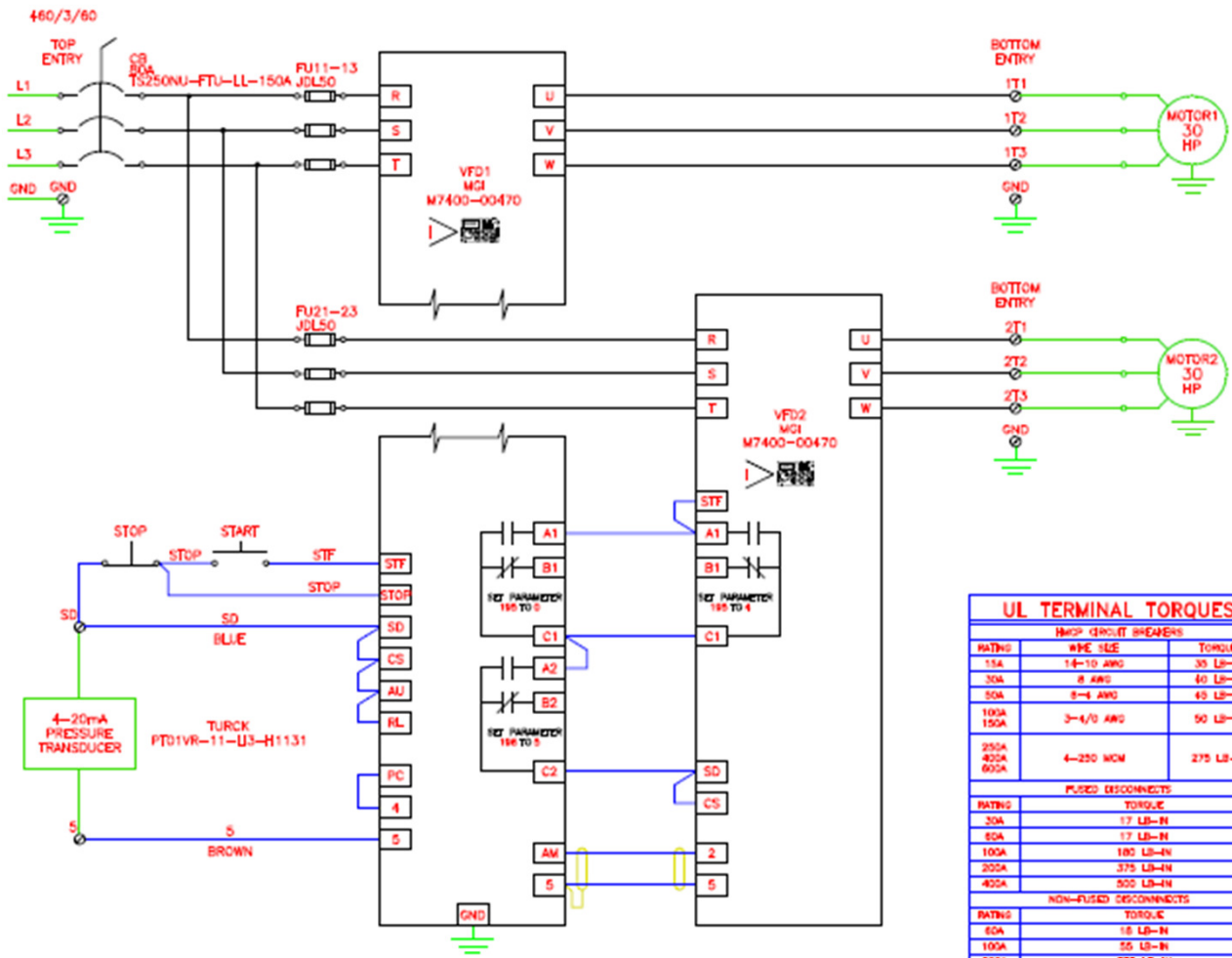

| UL TERMINAL TORQUES | | |
|---------------------------|-----------|----------|
| MCP CIRCUIT BREAKERS | | |
| RATING | WIRE SIZE | TORQUE |
| 15A | 14-10 AWG | 35 LB-IN |
| 30A | 8 AWG | 40 LB-IN |
| 50A | 8-4 AWG | 45 LB-IN |
| 100A | 3-1/0 AWG | 50 LB-IN |
| 150A | | |
| 250A | | |
| 400A | | |
| 600A | | |
| FUSED DISCONNECTS | | |
| RATING | TORQUE | |
| 30A | 17 LB-IN | |
| 50A | 17 LB-IN | |
| 100A | 180 LB-IN | |
| 200A | 375 LB-IN | |
| 400A | 500 LB-IN | |
| NON-FUSED DISCONNECTS | | |
| RATING | TORQUE | |
| 50A | 18 LB-IN | |
| 100A | 55 LB-IN | |
| 200A | 375 LB-IN | |
| 400A | 500 LB-IN | |
| WPE TERMINALS | | |
| TYPE | TORQUE | |
| SAF-4 | 8 LB-IN | |
| SAF-6 | 14 LB-IN | |
| SAF-10 | 18 LB-IN | |
| SAF-18 | 21 LB-IN | |
| SAF-35 | 41 LB-IN | |
| POWER DISTRIBUTION BLOCKS | | |
| WIRE SIZE | TORQUE | |
| 2/0-3 AWG | 120 LB-IN | |
| 350-500 MCM | 375 LB-IN | |

TAG: 480-4306

- DRIVE CONNECTION TERMINAL**
- DEVICE CONNECTION TERMINAL**
- TERMINAL NOT FOR CUSTOMER CONNECTION**
- TERMINAL FOR CUSTOMER CONNECTION**
- D** LOCATED ON ENCLOSURE DOOR
- I** LOCATED INSIDE ENCLOSURE
- R** LOCATED REMOTE FROM ENCLOSURE
- C** LOCATED IN RESISTOR CAGE
- ARROW SUPPLIED ENCLOSURE WIRING
- CUSTOMER SUPPLIED ENCLOSURE WIRING
- ARROW SUPPLIED FIELD WIRING
- CUSTOMER SUPPLIED FIELD WIRING
- OUTPUT ASSIGNMENT SUPPLIED PLC OUTPUT
- INPUT ASSIGNMENT SUPPLIED PLC INPUT
- OUTPUT ASSIGNMENT CUSTOMER PLC OUTPUT
- INPUT ASSIGNMENT CUSTOMER PLC INPUT

| ENCLOSURE | NEMA1 | VFC | VENTED | COLOR | DRY WET | DRY | WET | DRY |
|-----------|-----------|-------------------------------------|--------|-------|---------|-----|-----|-----|
| | | | | | NONE | 36 | 36 | 8 |
| REV. | DATE | DESCRIPTION | | | | | | |
| 0 | 10-MAY-11 | ORIGINAL DRAWING ISSUE - WEIGHT TBD | | | | | | |

CUSTOMER NAME: _____ CUSTOMER DRAWING NUMBER: _____ PLANT: _____

- Texas Star Express

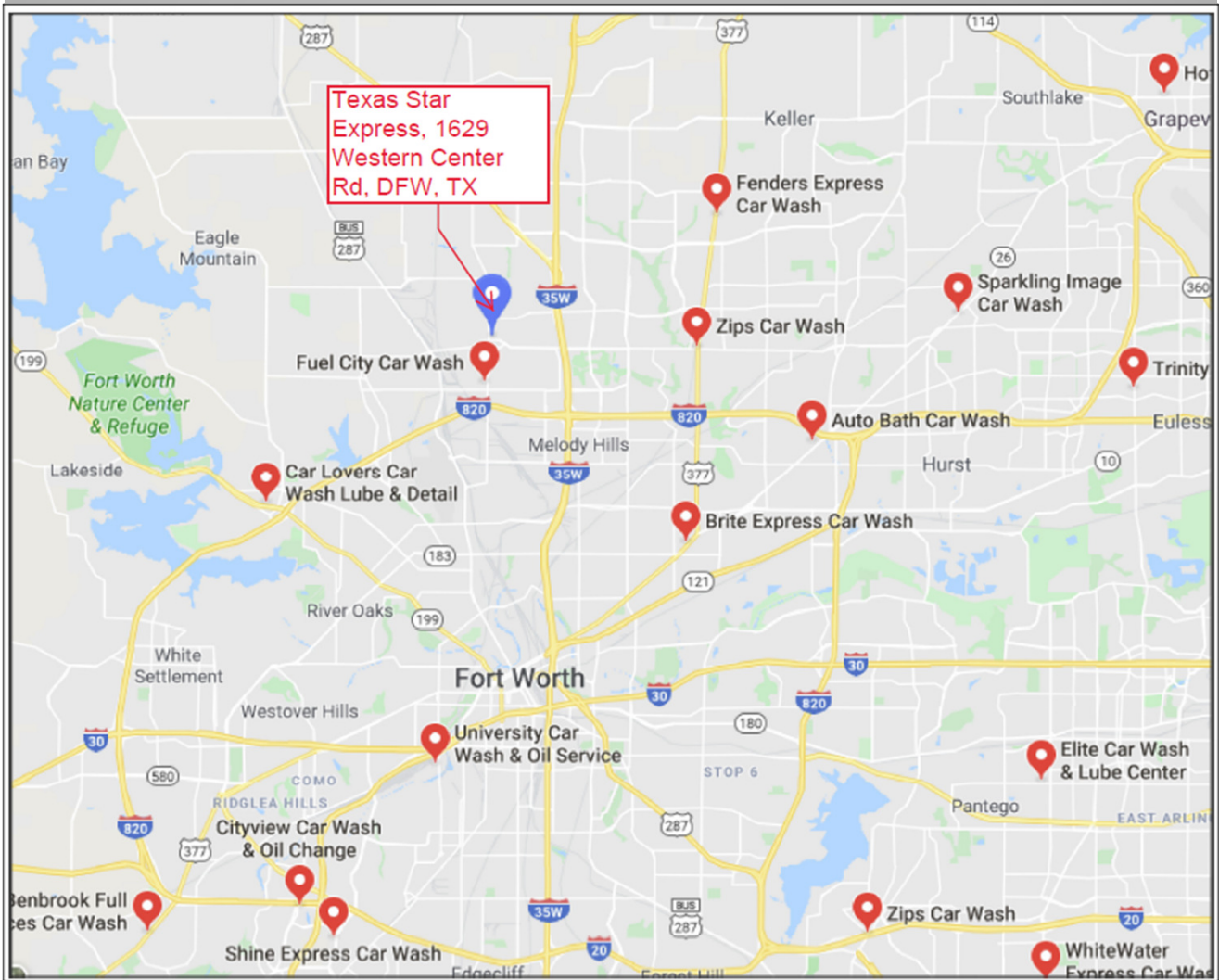

Competition Map

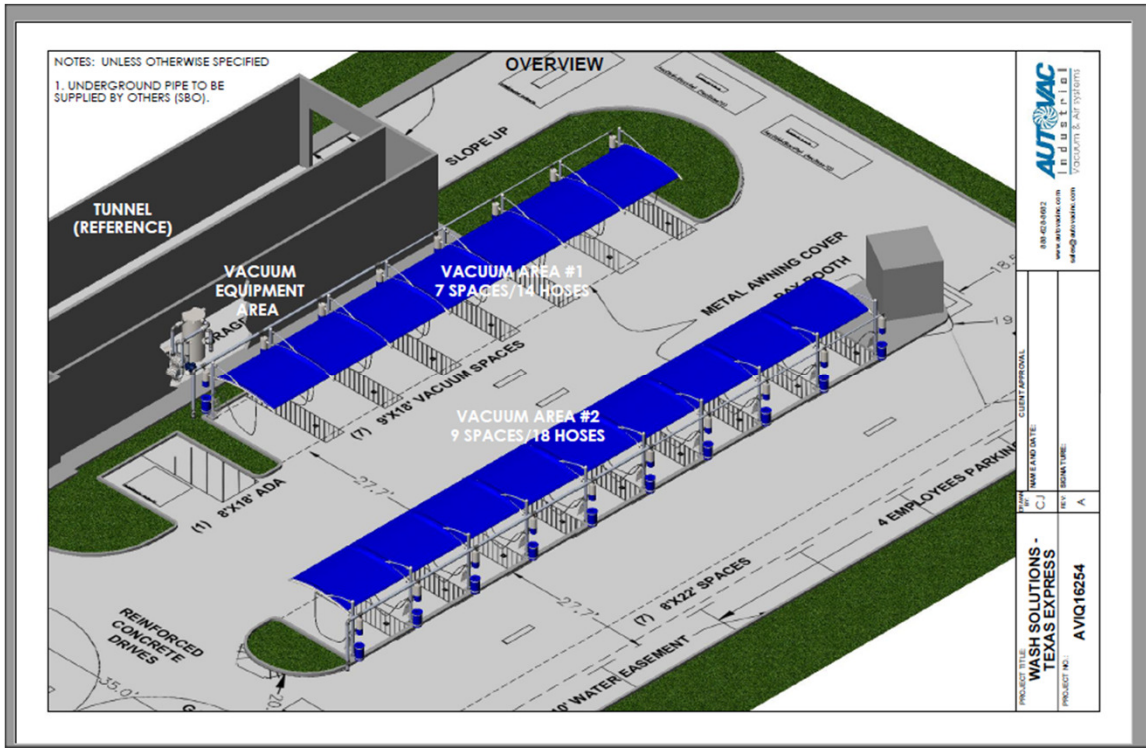







Roger A. Pencek
Designated Broker
President, M.B.A.

Web Page
www.carwashbrokers.com
www.abibiz.com

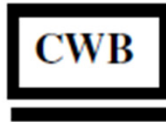

Corporate Office
Phone: (602) 787-1100
Fax: (480) 483-1116
Mobile: (602) 770-4040

Car Wash Brokers, Inc.
(aka) ABI, LLC
11408 N. Blackheath Rd
Scottsdale, Az 85254



Roger A. Pencek
President / Broker / Principal / Consultant / M.B.A.

Experienced Real Estate Broker in Selling, Marketing and consulting in the Car Wash Business since 1985. Roger molded his early Merger and Acquisitions career in management capacity at General Motors Corporation and International Harvester upon graduation from Western Illinois University in 1974 with his BS degree. His MBA was obtained 1985 from the University of Phoenix.

Since 1985 he has founded and owns ABI L.L.C. (Acquisitions, Businesses & Investments L.L.C.) which specializes in the sale of businesses in the \$250K - \$20M range. For the last twenty five years he has gained the reputation of "**Car Wash Broker**," specializing in the sale of washes and gas stations in the Pacific Southwest (AZ, CA, CO, NV, TX).

Today, he now also has to his credit, created and owns "Car Wash Brokers, Inc.," (CWB, Inc.), a National Company solely specializing in the sale of **Full Service, Express and Self Service Car Wash Businesses** in the USA! His goal is to have CWB Inc., agents in every state of the USA and representation in Canada and Europe.

Roger is an expert court witness and testimony for car wash related cases, a frequent and revered public speaker, pro bono author's articles for Car Wash Associations and magazines.

CWB Inc., Mission Statement: CWB is national network of licensed agents marketing existing car washes to the public, in an ethical and professional manner acknowledged as the expert in the industry.

CWB Inc., web site www.carwashbrokers.com will provide further references and Car Wash credentials.

Roger Pencek

Designated Broker, President
10930 N Tatum Blvd, #106
Phoenix, AZ. 85028

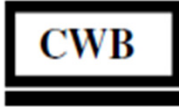

Branch Offices ** USA

Corporate Office

Office: (602) 787-1100
Fax: (480) 483-1116
Mobile: (602) 770-4040
roger@carwashbrokers.com

Web Page

www.carwashbrokers.com



Car Wash Brokers, Inc.

Corporate Office
11408 N Blackheath Rd
Scottsdale, Az. 85254
(602) 787-1100



"CONFIDENTIALITY AGREEMENT REGISTRATION FORM"

It is hereby agreed between _____ (and/or assigns hereinafter referred to as "Potential Buyer") and Car Wash Brokers, Inc. (CWB) and its duly authorized agent and Roger Pencek (Together referred to as "Broker") that, in exchange for broker disclosing certain information regarding the business listed and described below (hereinafter referred to as the "Business") to potential buyer, and warrants that their signature below is their true identity.

1. Potential Buyer will not interview employees or representatives of the business without the express, written consent of broker;
2. Potential Buyer will treat forms used by broker as CONFIDENTIAL and will not disclose them or permit them to be used by anyone not specifically authorized by broker;
3. For each business listing provided by CWB buyer agrees to utilize the brokerage services of CWB on the business as introduced to buyer. If buyer violates this condition, buyer agrees to pay CWB sellers pre-negotiated commission in full, directly to CWB. This agreement will survive for one year from the date below.
4. Seller has provided all information contained on this form, BROKER HAS NOT AUDITED, VERIFIED OR INVESTIGATED any of the information. Potential buyer should investigate and verify all representations regarding the business with seller. Potential buyer understands that broker is acting as agent for seller and that this offering is subject to prior sale.
5. The undersigned also states that the reason for their inquiry is their interest in purchasing the business and not to gain information for other competitors or an assigns for the Department of Internal Revenue Services.
6. It is further agreed that in the event of any breach or threatened breach of this agreement, broker may, in addition to any other remedies it may have, obtain an injunction restraining potential buyer and any of its agents or employees from disclosing or using any information or knowledge obtained from broker pursuant to this agreement. Potential buyer hereby consents to the jurisdiction of the Superior Court of the state is authorized, for such purposes and for the determination of all other remedies under this agreement.
7. The undersigned potential Buyer acknowledges the responsibility to perform a due diligence review at his own cost and expense prior to any acquisition with CWB, and will deal exclusively with CWB in any acquisition CWB has registered below with potential buyer within 1 (one) year of the date hereof.
8. In the event agent listed below is eligible for a fee from Buyer's lender, this is disclosure of the same.

Note: any co-broke or referral fees for buyers agents are to be disclosed upon authorization below.

None

I the undersigned "Buyer" have read all of the terms and conditions above. I fully understand the information that I have read and understand what my responsibilities are. I also understand that legal actions will be taken against me in the case of a breach or threat to breach this contract with CWB.

Please authorize and scan back..thank you

Roger A Pencek

Potential Buyer: _____

_____ Date

A.B.I. Authorized Agent
Roger A Pencek

Address: _____
Phone: _____

| | | | | |
|-----------------------|---------------------------------|-------|--------|---------|
| Texas Star Express CW | 1629 Western Center Rd, DFW, TX | Cash | \$3.2M | Express |
| _____ | _____ | _____ | _____ | _____ |
| _____ | _____ | _____ | _____ | _____ |
| _____ | _____ | _____ | _____ | _____ |



Car Wash Brokers, Inc.

11408 North Blackheath Road, Scottsdale, AZ 85254



We Sell Car Washes!

Full Service • Express • Self-Service



- Largest Car Wash Brokerage In U.S.A. (Est. 1985)
- Car Wash and Gas Station Brokers & Consultants



www.carwashbrokers.com

Roger A. Pencek - President, Broker, Consultant
 602-787-1100
 Roger@carwashbrokers.com



Est. 1985



ROGER A. PENCEK
 DESIGNATED BROKER
 PRESIDENT/M.B.A.



Car Wash Brokers, Inc.
(aka) Acquisitions, Business, & Inv. LLC
 11408 N. Blackheath Rd.
 Scottsdale, AZ 85254

Web Page: www.carwashbrokers.com

CORPORATE OFFICE

11408 N. Blackheath Rd.
 Scottsdale, AZ 85254
Phone: (602) 787-1100
Mobile: (602) 770-4040
Email: roger@carwashbrokers.com