

FOR LEASE

# 1871

## BAILEY ROAD

Cuyahoga Falls, OH 44221



### PROPERTY DETAILS

- + Affordable office space located less than one (1) mile from Downtown Cuyahoga Falls and Route 8
- + Office space options ranging from 3,880 RSF–11,640 RSF
- + Lower level storage
- + Three (3) story multi-tenant building
- + Elevator to all floors
- + Signage available
- + Free surface parking in front and rear of building
- + Modified Gross Lease rate:
  - First Floor: \$12 per RSF
  - Second & Third Floor: \$10 per RSF
- + Tenant responsible for: prorated share of utilities in-suite cleaning and in-suite maintenance
- + Tenant improvement allowance of \$10 per RSF for a five (5) year lease
- + Owner willing to expand first floor to 7,760 RSF



### CONTACT US

#### GARY RICKEL

Vice President  
+1 330 670 4414  
gary.rickel@cbre.com

#### ZADA LINES

Associate  
+1 330 670 4418  
zada.lines@cbre.com

#### CBRE INC.

3421 Ridgewood Road  
Suite 150  
Akron, OH 44333

[www.cbre.com/akron-canton](http://www.cbre.com/akron-canton)

**CBRE**

FOR LEASE



First Floor Plan – 3,880 RSF

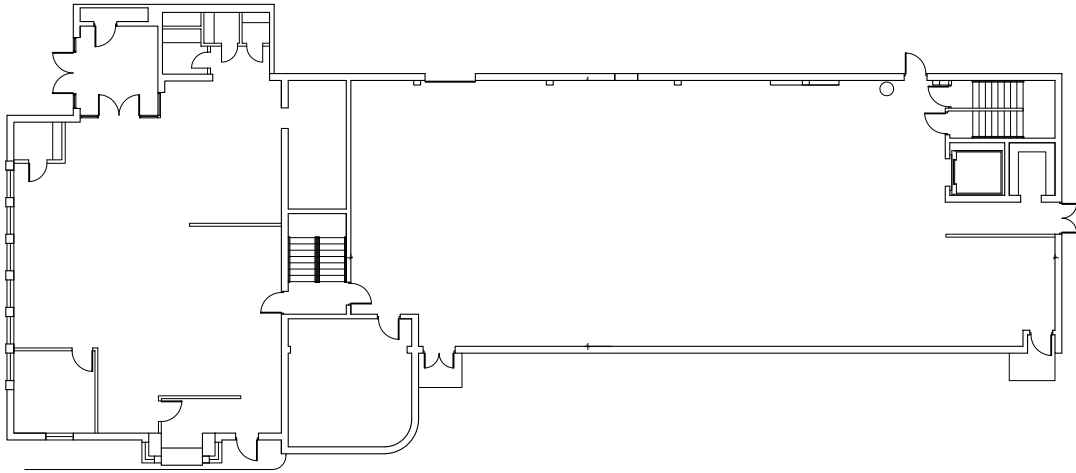

Second Floor Plan – 3,880 RSF

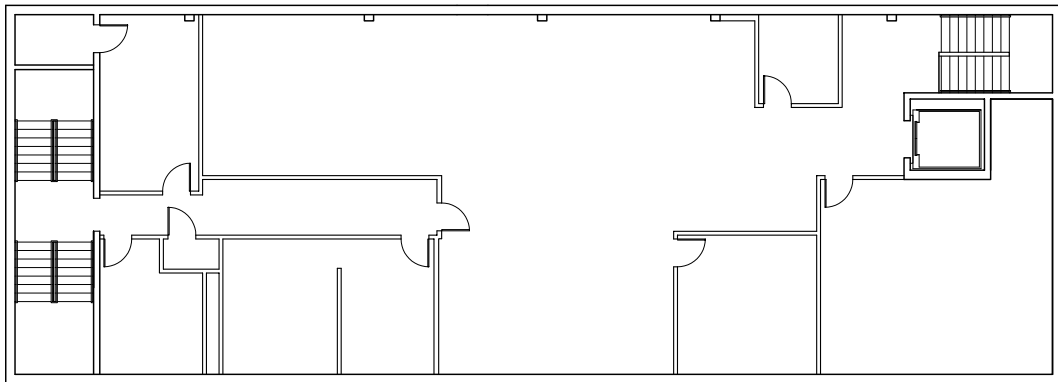

Third Floor Plan – 3,880 RSF

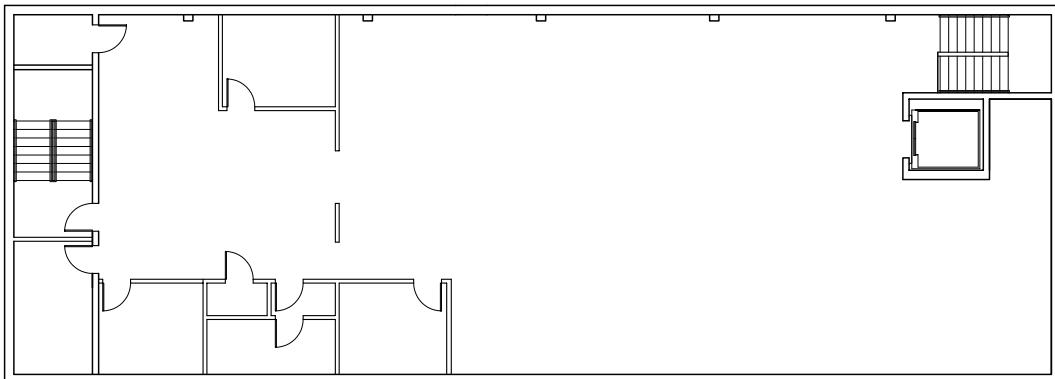



Conceptual Rendering for additional 3,880 RSF on first floor  
 (Total: 7,760 RSF on first floor)

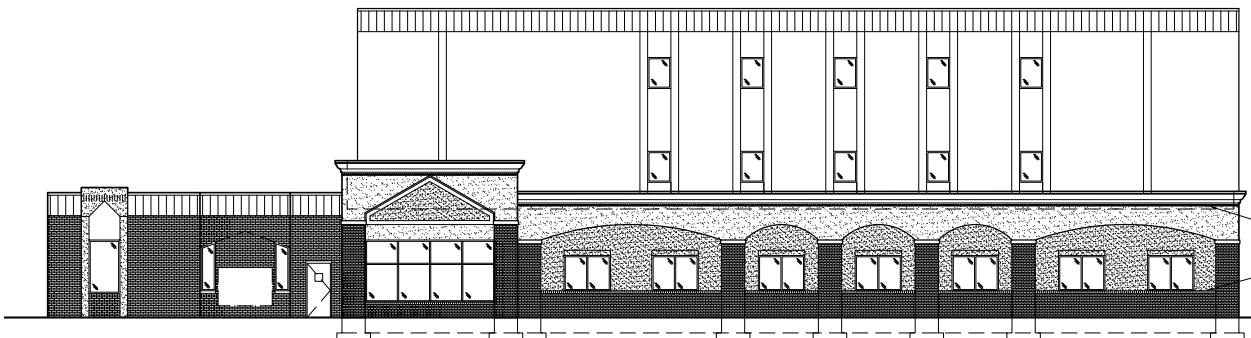

WEST ELEVATION  
 SCALE: 3/32" = 1'-0"

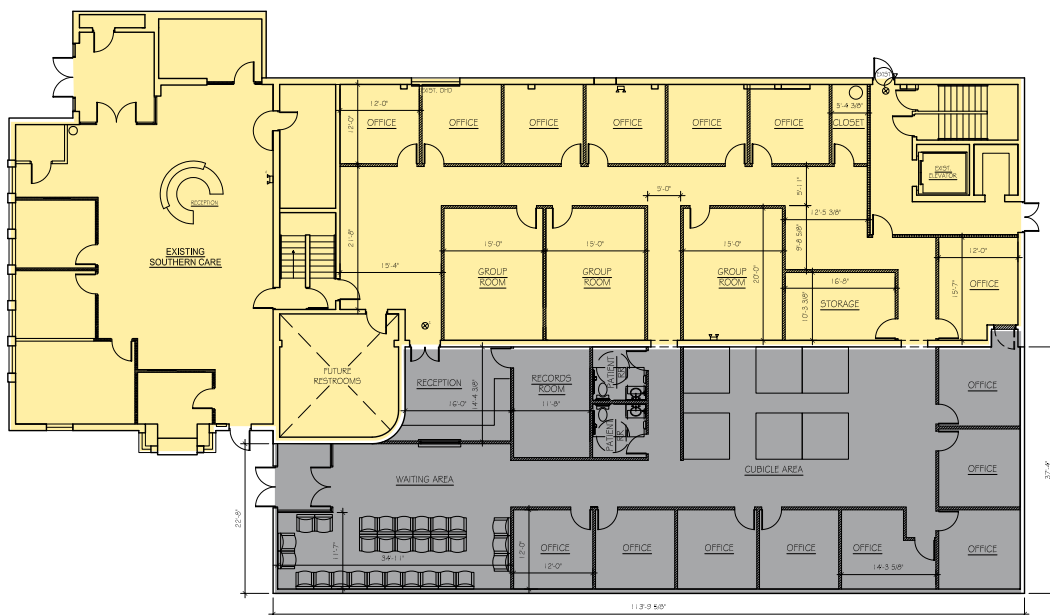

FIRST FLOOR PLAN  
 SCALE: 3/32" = 1'-0"

Conceptual Floor Plan Revised  
 SCALE: 3/32" = 1'-0"

- Existing Space
- Expansion Space

FOR LEASE

1871  
**BAILEY ROAD**  
Cuyahoga Falls, Ohio 44221

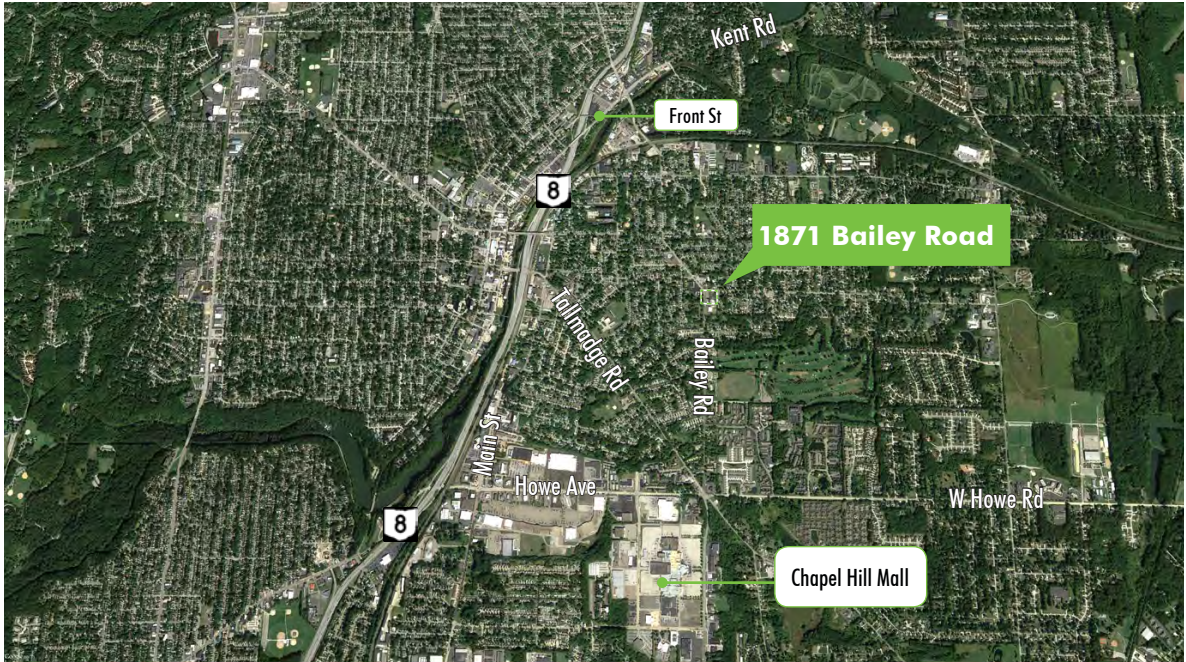

## CONTACT US

### **GARY RICKEL**

Vice President  
+1 330 670 4414  
gary.rickel@cbre.com

### **ZADA LINES**

Associate  
+1 330 670 4418  
zada.lines@cbre.com

### **CBRE INC.**

3421 Ridgewood Road  
Suite 150  
Akron, OH 44333

© 2016 CBRE, Inc. This information has been obtained from sources believed reliable. We have not verified it and make no guarantee, warranty or representation about it. Any projections, opinions, assumptions or estimates used are for example only and do not represent the current or future performance of the property. You and your advisors should conduct a careful, independent investigation of the property to determine to your satisfaction the suitability of the property for your needs. Photos herein are the property of their respective owners and use of these images without the express written consent of the owner is prohibited. CBRE and the CBRE logo are service marks of CBRE, Inc. and/or its affiliated or related companies in the United States and other countries. All other marks displayed on this document are the property of their respective owners.

[www.cbre.com/akron-canton](http://www.cbre.com/akron-canton)

**CBRE**