

To Let

6 Randolph Crescent
Edinburgh
EH3 7TH

1,229 sq ft to 5,468 sq ft

114 sq m to 508 sq m

- ENTIRE TOWNHOUSE
- VARIOUS SPLIT OPTIONS AVAILABLE
- EXCELLENT CITY CENTRE LOCATION
- EPC: D
- ATTRACTIVE OUTLOOK
- PROMINENT SITUATION

ftlinden
.com



Location

6 Randolph Crescent is located in the heart of the West End, just off Queensferry Road, within Edinburgh's historic New Town.

The city centre and numerous transport links, to include key bus stops and the 'West End' tram halt, are c.6 minutes walk. Haymarket and Waverley train stations are approximately 13 and 20 minutes walk respectively from the property.

Description

6 Randolph Crescent comprises a mid-terraced, self-contained, Grade A-listed townhouse over lower ground, ground, first, second and third floor levels, accessed via a very attractive main door/entrance hall at raised ground floor level. The lower ground floor can be accessed separately from street level and could be split to offer a be self-contained floor.

At present there is a commercial kitchen in the lower ground floor with a dumbwaiter to the first floor. There are tea prep / kitchen facilities on the ground, first and second floors and excellent WC provision across all but the first floor.

There is excellent storage in the property as well as cellars at the front and rear. The well maintained rear garden provides access onto Randolph Lane.

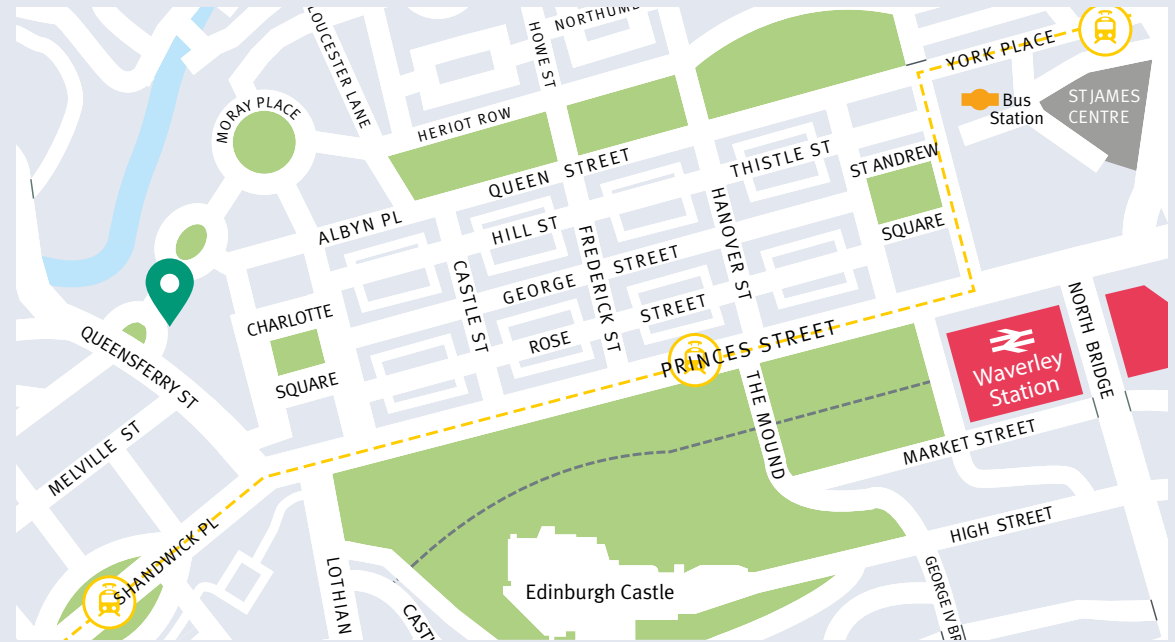

Accommodation

The subjects have been measured in accordance with the RICS Code of Measuring Practice (6th Edition) and the Net Internal Area extends to approximately:

FLOOR	SQ FT	SQ M
Lower Ground	1,229	114.2
Ground	1,028	95.5
First	1,249	116
Second	1,110	103.2
Third	852	79
TOTAL	5,468	508
Plus storage		

We are able to let separately:

FLOOR	SQ FT	SQ M
Lower Ground (Self Contained)	1,229	114.2
Lower Ground and Ground	2,257	237.55
Lower Ground, Ground and First	4,506	418.6

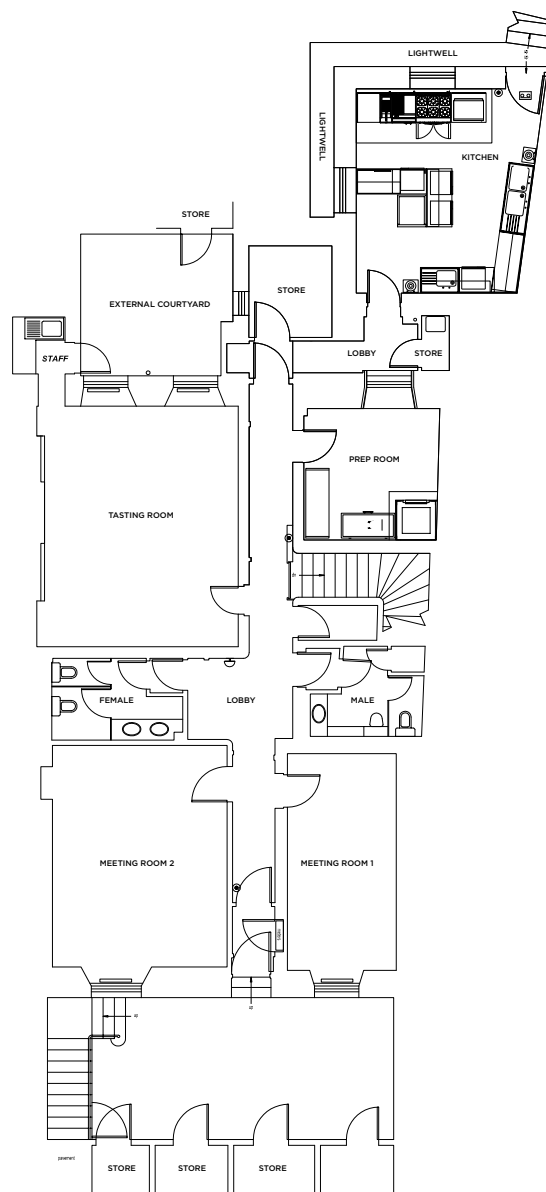

BASEMENT

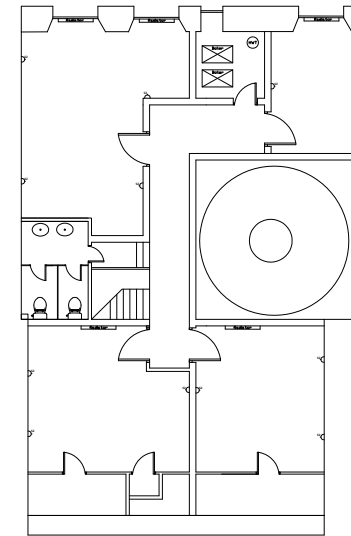

THIRD FLOOR

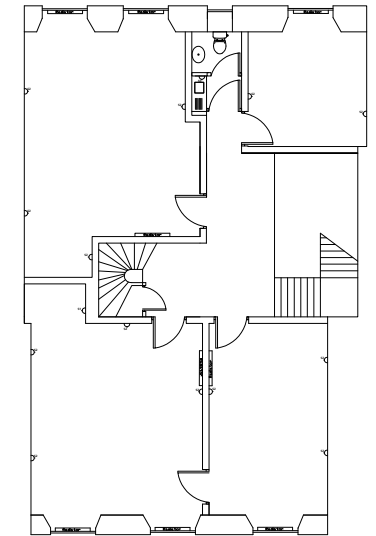

SECOND FLOOR

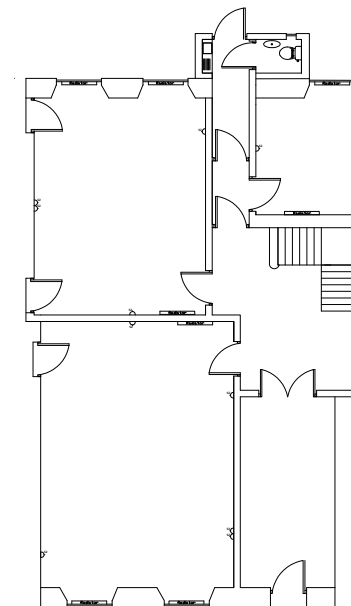

GROUND FLOOR

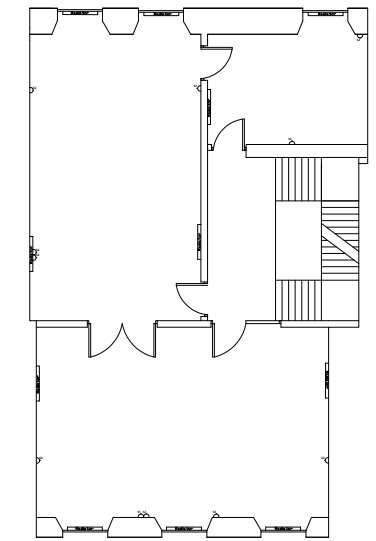

FIRST FLOOR



Lease Terms

The property or part there of, is available on flexible terms.

Rent

Available on request.

Rateable Value

The subjects will require assessment on occupation. It is expected that tenants (subject to status) may benefit from Small Business Rates Relief if taking a single floor.

Legal Costs

Each party shall be responsible for their own reasonable incurred costs.

VAT

All prices premiums etc are quoted exclusive of VAT.

Viewing & Further Information

Strictly by appointment through the sole agent:

Angus Thomson MRICS

angus.thomson@ftlinden.com

John Morton MRICS

john.morton@ftlinden.com



FT Linden Ltd
28 Stafford Street
Edinburgh
EH3 7BD

www.ftlinden.com