



90TH ST E

WALLER RD E

LEASED

SHARED DRIVE AISLE

LEASED

OFFICE

SHOP

CARPORT

SHED

→ VIEW PROPERTY PHOTOS

FOR LEASE ————— 9021 WALLER RD E, TACOMA, WA

*±100,000 SF IOS Yard with
Shop and Office*

\$20,000

PER MONTH + NNN

Exclusively listed by

MATT MCLENNAN, SIOR, CCIM
253.722.1458
matt.mclennan@kidder.com

Property Overview

OFFICE AVAILABILITY

LAND SIZE ±100,000 SF

OFFICE SIZE 1,288 SF

SHOP SIZE 3,270 SF

CARPORT 420 SF

SHED ±275 SF

LOADING 4 Grade Level

RATE
Lease: \$20,000/month
NNN: \$750/month (estimated)
Total: \$20,750/month



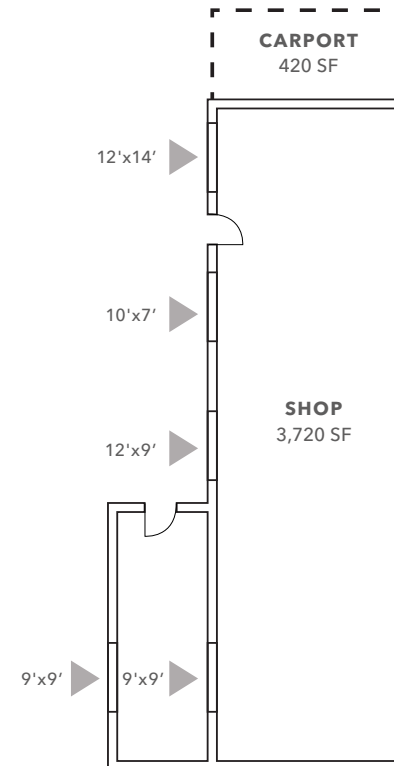
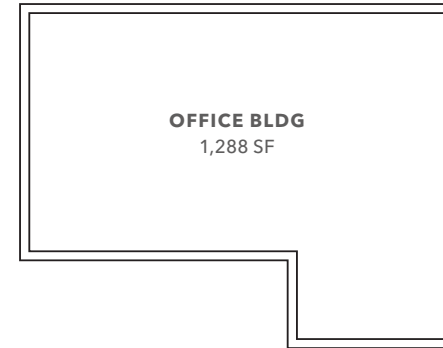

▲ Grade level loading





9021 WALLER RD E

*For more information on
this property, please contact*

MATT MCLENNAN, SIOR, CCIM
Executive Vice President
253.722.1458
matt.mclennan@kidder.com

KIDDER.COM

This information supplied herein is from sources we deem reliable. It is provided without any representation, warranty, or guarantee, expressed or implied as to its accuracy. Prospective Buyer or Tenant should conduct an independent investigation and verification of all matters deemed to be material, including, but not limited to, statements of income and expenses. Consult your attorney, accountant, or other professional advisor. All Kidder Mathews designs are the sole property of Kidder Mathews. Branded materials and layouts are not authorized for use by any other firm or person.

