

NOW LEASING

FREESTANDING BUILDING FOR LEASE

± 2,394 SF PRIME RETAIL/OFFICE

2015 E 7th Avenue, Tampa, FL 33605

GNP
DEVELOPMENT

CASA YBOR
RETAIL | RESIDENTIAL | OFFICE

FLOOR PLAN, PROPERTY HIGHLIGHTS & VIRTUAL TOUR

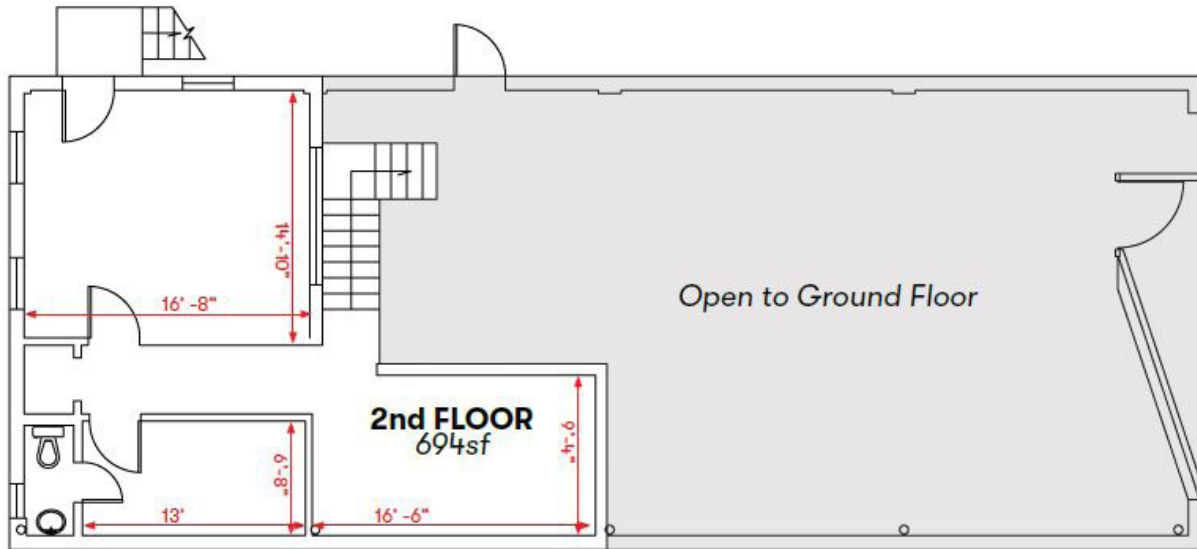
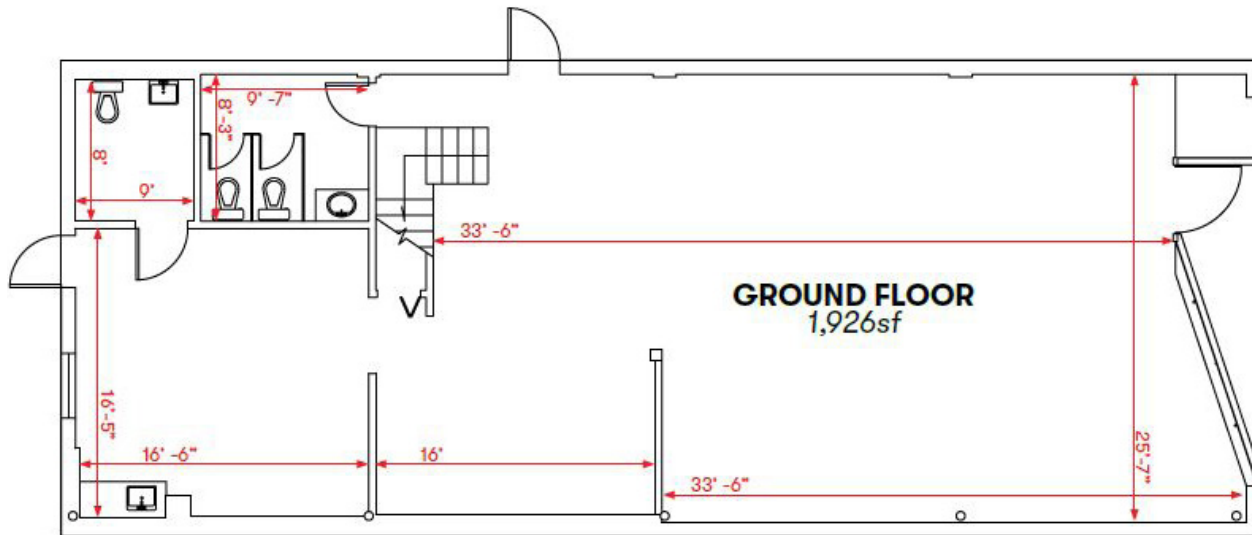

Second Floor
Mezzanine Space

Located on
7th Avenue

Adjacent
Well-Known
Columbia Restaurant

PROPERTY PHOTOS

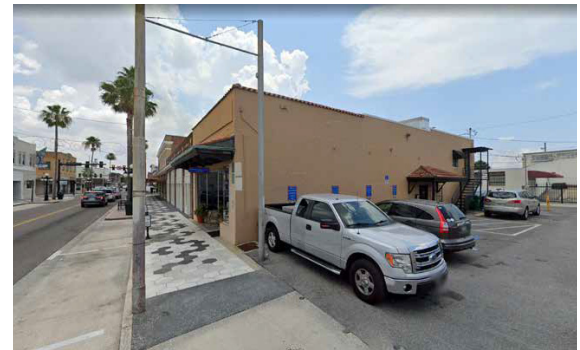

AT THE CENTER OF TAMPA'S HOSPITALITY COMMUNITY

Hospitality Snapshot



Residents (2023)

Dining expenditures
\$2.1 billion - Tampa/Hillsborough
\$1.6 billion - St. Pete/Pinellas

Tourism (2022)

\$5.4 billion total spending
of which: \$1.5 billion on dining
109% of 2019 visitor levels
16M daytime visitors
11M overnight visitors

Port Tampa Bay

Largest port in Southeast, serving:
Carnival
Norwegian
Royal Caribbean

Amalie Arena

200 events per year
2 million guests per year

Michelin Guide - FL (2023)

Listed
18 Restaurants

1-Star	Bib Gourmand
Rocca	Gorkhali Kitchen
Lilac	Rooster and Till
Koya	Psomi

A RICH HISTORY OF ART & HOSPITALITY

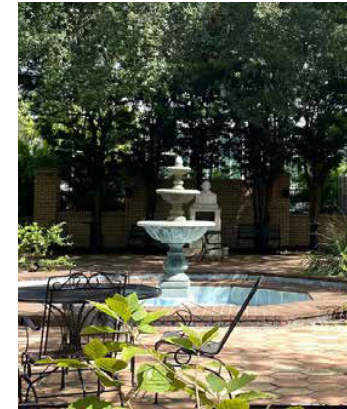

“Ybor’s social clubs all had libraries, dance halls, and canteens where folks gathered in the evening. At the Centro Asturiano we saw zarzuelas per-formed by local amateurs. . . . I remember as a boy going to a free art class summer evenings at the Círculo Cubano.”

JOSE YGLESIAS, NUESTRA (1977)
MICHELIN GUIDE 2023 - FLORIDA



NOW LEASING

2015 E 7TH AVENUE, TAMPA, FL

CONTACT:

CLAIRE CHAPIN

CLAIRECHAPIN@GNPDEV.COM

646.764.3036

JOSHUA PARDUE

JOSHPARDUE@GNPDEV.COM

646.634.0888

COOPER ROSARIO

COOPERROSARIO@GNPDEV.COM

352.223.8319

GNP
DEVELOPMENT



CASA YBOR
RETAIL | RESIDENTIAL | OFFICE