

304 KING ST



Modern Retail Meets Southern Charm

Nothing defines Southern charm quite like King Street. Known as “The Only High Street in the Carolinas,” King Street boasts some of the city’s trendiest restaurants and sophisticated cocktail bars along with hotels, art galleries, flourishing businesses, lively nightlife, and exceptional shopping. Its wide, pedestrian-friendly sidewalks, chic boutiques, antique shops, three-story brick buildings, and central location make it easy to see why King Street is an unforgettable dining and shopping experience.

“TOP CITY IN THE UNITED STATES”

TRAVEL + LEISURE

“10 TOP SHOPPING DISTRICTS IN THE USA”

FORBES TRAVELER

“TOP 10 SHOPPING STREETS”

U.S. NEWS AND WORLD REPORT



Charleston At-A-Glance

7.3 MILLION
ANNUAL VISITORS

24%
CHARLESTON COUNTY SALES
ATTRIBUTED TO TOURISM

\$8 BILLION
TOTAL ANNUAL ECONOMIC
IMPACT OF TOURISM

10,384
ENROLLED AT THE COLLEGE
OF CHARLESTON
(1-BLOCK AWAY)

AVERAGE DAILY SPENDING

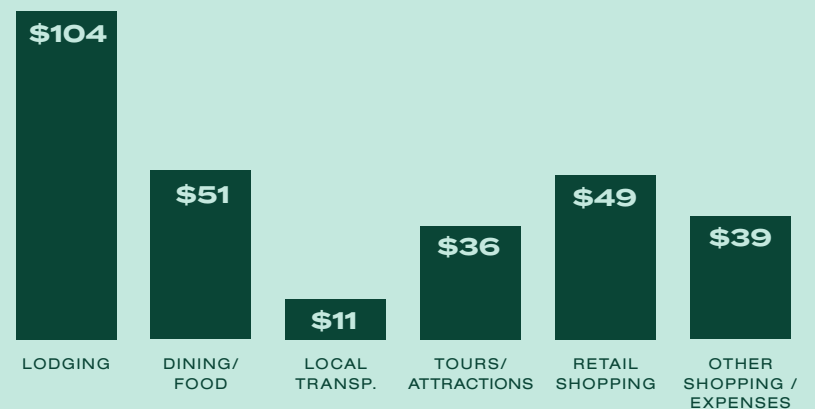

Flexible F&B Opportunity



Flexible F&B Opportunity



SINGLE-STORY OPTION



TWO-STORY OPTION

Across from Apple in the Heart of King Street



HASSELL ST

WENTWORTH ST

SOCIETY ST

GEORGE ST

BURNS LN

CALHOUN ST

- VICTORIA'S SECRET
- CLUB MONACO
- ANTHROPOLOGIE
- J. CREW
- WORTHWHILE
- KENDRA SCOTT
- CANDLEFISH

- SAVANNAH BEE
- **MADEWELL**
- UNTUCKIT
- MARINE LAYER
- THE QUARTERS ON KING

- M. DUMAS & SONS

304 KING ST

- SALT LIFE
- SMALL
- THE OOPS!

- NEW HOTEL / CONDOS
- JUDE CONNALLY
- FRANCESCA'S
- CO
- VOM FASS
- THE COPPER CLOSET
- MORA
- YETI

- FIVE GUYS
- CHIPOTLE
- WALGREENS

MEETING ST

MARION SQUARE

KING ST

KING ST

- PALM AVENUE
- SCOTCH & SODA

- VINEYARD VINES
- LULULEMON
- **H&M**
- STEVE MADDEN
- SEPHORA

LIBERTY ST

- QUICKSILVER
- **APPLE**

- VANS
- CHASE BANK
- COPPER PENNY
- POTTERY BARN

- CHUBBIES
- VERDE

- SEE EYEWEAR

- WILLIAMS-SONOMA
- URBAN OUTFITTERS
- GOORIN BROS
- MOE'S

ST. PHILIP ST

COLLEGE OF CHARLESTON

COMING ST

- RETAIL
- DINING
- HOTELS



Floor Plan

Single-Story



4,316 RSF

AVAILABLE

19-FOOT

CEILING HEIGHTS

26.5 FEET

OF FRONTAGE

FULL BUILDING

PRESENCE

NO RESIDENTIAL ABOVE

Floor Plan

Two-Story

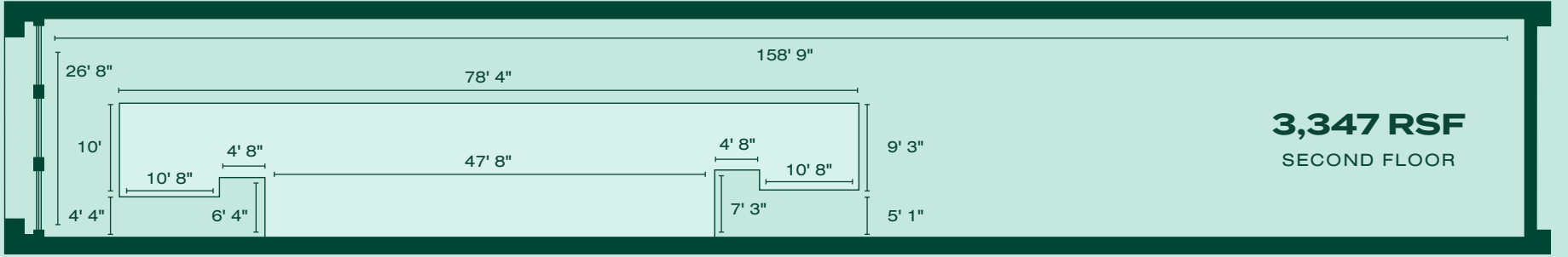
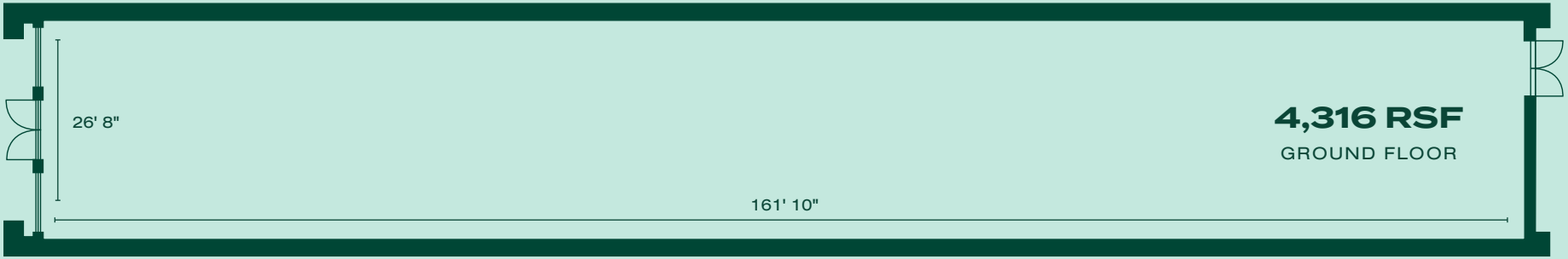

7,663 RSF
AVAILABLE

19-FOOT
CEILING HEIGHTS

26.5 FEET
OF FRONTAGE

FULL BUILDING PRESENCE
NO RESIDENTIAL ABOVE



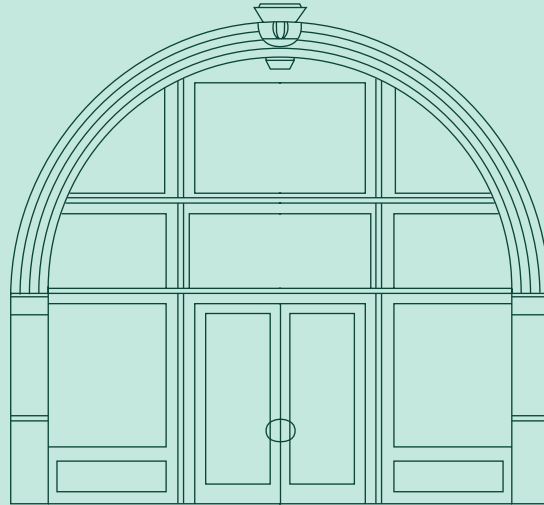

304 KING ST

JOSH SCHAAP

JOSH@CHARLESTONCONNECTION.NET
843.670.5727

CHRIS "KENDRICK"

KENDRICK@CHARLESTONCONNECTION.NET
843.475.1922

JACK CRENCIA

JACK@CHARLESTONCONNECTION.NET
240.328.4380

