

FOR LEASE

Alexander Village

2121 TW ALEXANDER DRIVE | MORRISVILLE, NC 27560

RETAIL



CONTACT US

Cristi Greene

Associate

+1 919 831 8188

cristi.greene@cbre-raleigh.com

© 2016 CB Richard Ellis-Raleigh, LLC, a Delaware limited liability company. This information has been obtained from sources believed reliable. We have not verified it and make no guarantee, warranty or representation about it. Any projections, opinions, assumptions or estimates used are for example only and do not represent the current or future performance of the property. You and your advisors should conduct a careful, independent investigation of the property to determine to your satisfaction the suitability of the property for your needs.

www.cbre.com/raleigh

CBRE | Raleigh

Part of the CBRE affiliate network

FOR LEASE

Alexander Village

2121 TW ALEXANDER DRIVE | MORRISVILLE, NC 27560

RETAIL



PROPERTY INFO

Anchored by Food Lion, Alexander Village is a ±78,000 SF community shopping center located in affluent Northwest Raleigh.

- + Within close proximity to Brier Creek shopping centers and several residential communities
- + Easy access to Research Triangle Park, Highway 70, I-540 and I-40
- + Excellent daytime traffic counts and strong area retail
- + 2nd anchor pad available that can be expanded for retail and non-retail users



2016 Demographics

	1 Mile	3 Miles	5 Miles
Population	7,775	27,295	75,377
Households	3,437	12,953	34,807
Average HH Income	\$103,140	\$98,637	\$95,628
Daytime Employees	2,454	29,627	90,852

www.cbre.com/raleigh

CBRE Raleigh
Part of the CBRE affiliate network

FOR LEASE

Alexander Village

2121 TW ALEXANDER DRIVE | MORRISVILLE, NC 27560

RETAIL

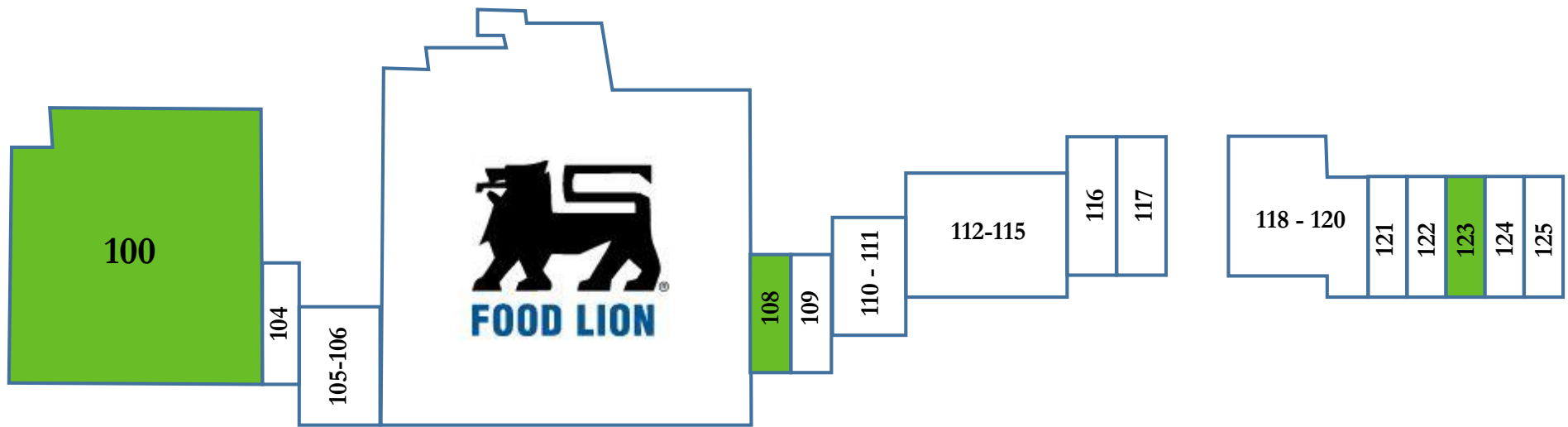

Suite #	Tenant	SF
100	AVAILABLE	16,830
104	Gentlemens Choice Barber	1,200
105	Durham County ABC Liquor	2,400
107	Food Lion	33,764
108	AVAILABLE	1,200
109	Smiles Dentistry	1,200
110-111	Mekong Vietnamese Restaurant	2,400
112	Anytime Fitness	4,800

Suite #	Tenant	SF
116	Subway	1,750
117	Randy's Pizza	1,750
118-120	La Cocina Mexican Restaurant	4,700
121	Hollywood Spa Nails	1,200
122	China Kitchen	1,200
123	AVAILABLE	1,200
124	State Farm Insurance	1,200
125	Sunshine Cleaners	1,200

FOR LEASE

Alexander Village

2121 TW ALEXANDER DRIVE | MORRISVILLE, NC 27560

RETAIL

