

Engineering Analysis

**Sherwin Williams Building
5408 Douglas
Des Moines, IA**

for:

**Joe Jester Real Estate
jjjester@mchsi.com**

Attn: Joe Jester

by:

Tomefich Engineering, Inc.

10501 Buena Vista Court
Urbandale, Iowa 50322
Phone: (515) 280-8022
Fax (515) 727-9124

e-mail: jet@tomefichengineering.com
web site: www.tomefichengineering.com

P21-065
28-Apr-21

Tometich Engineering, Inc.
Urbandale, Iowa 50322
Phone: (515) 280-8022
Fax: (515) 727-9124

Job Name: Sherwin Williams Buil p. 1/15
Job # P21-065
file: P21-065
Date: 28-Apr-21

calc1.xls
Date: 28-Apr-21

Sherwin Williams Building

Design Calculations:

Project : Sherwin Williams Building
4503 Douglas
Edes Moines, IA

Submit to: Joe Jester Real Estate
jjjester@mchsi.com

Phone: phone
Fax: fax
e-mail: jjet@

Design Review:

James E. Tometich, P.E.
Tometich Engineering, Inc. Iowa Reg. # 11121
Colorado Reg # PE39511 No. Carolina Reg # 026324
Kansas Reg # 19988 Texas Reg. # 103153
Nebraska Reg # E-7577 Wisconsin Reg # E-40297

References:

AISC Manual for Steel Construction; 15th Ed. (AISC 360-16)
American Concrete Institute; ACI 318-14
American Wood Council (AWC); NDS 2018
International Building Code (IBC) - 2018 Edition

Commentary:

This project consists of load rating
an existing concrete slab

Certification:

I hereby certify that this engineering document was prepared by me
or under my direct personal supervision and that I am a duly
licensed Professional Engineer under the laws of the State of Iowa

Signature: 
Date: 29 APR. 2021
Registration #: 11121

My Registration Expires December 31, 2022

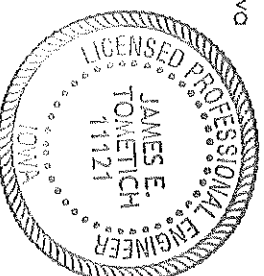

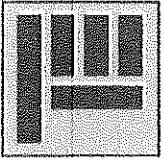

Tometich Engineering, Inc.
consulting structural engineers

2/15

10501 Buena Vista Ct. Urbandale, IA 50322

Date: April 28th, 2021
Job #: P21-065
To: Joe Jester Real Estate
Attn: Joe Jester
Re: 5408 Douglas Avenue

Tometich Engineering recommends the use of an Expanding Structural Polymer (ESP) to fill the voids under the existing slab. Soil stabilization with the ESP is also recommended. The attached calculations use properties from CST-003 polymer (data sheet attached within). A similar ESP is acceptable.

Once the void has been filled and the soil stabilized, the slab is adequate for the proposed loading by Sherwin-Williams. We recommend the use of a "sleeper" - either a 2x6 or 1/2" steel plate under the storage rack columns to help distribute the load. See sketch on page 3. See attached calculations.

Please call if we may be of further assistance.
Sincerely,

Jim Tometich, P.E.
Tometich Engineering, Inc.

Please call if I may be of further assistance.

Certification:

I hereby certify that this engineering document was prepared by me
or under my direct personal supervision and that I am a duly
Registered Professional Engineer under the laws of the State of Iowa.

Signature: *J Tometich*

Date: April 29, 2021 Registration #: 11121

My Registration Renewal Date is December 31, 2022

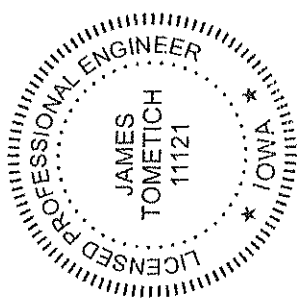

Tometich Engineering, Inc.

10501 Buena Vista Court
Urbandale, Iowa 50322

(515) 280-8022

fax: (515) 727-9124

www.tometichengineering.com

PROJECT JESTER

SHEET NUMBER 3 OF 15

CALCULATED BY KJD DATE 4/29/21

CHECKED BY _____ DATE _____

FILE NUMBER P21-0165

JESTER - SUPERIOR SKYTRAIL

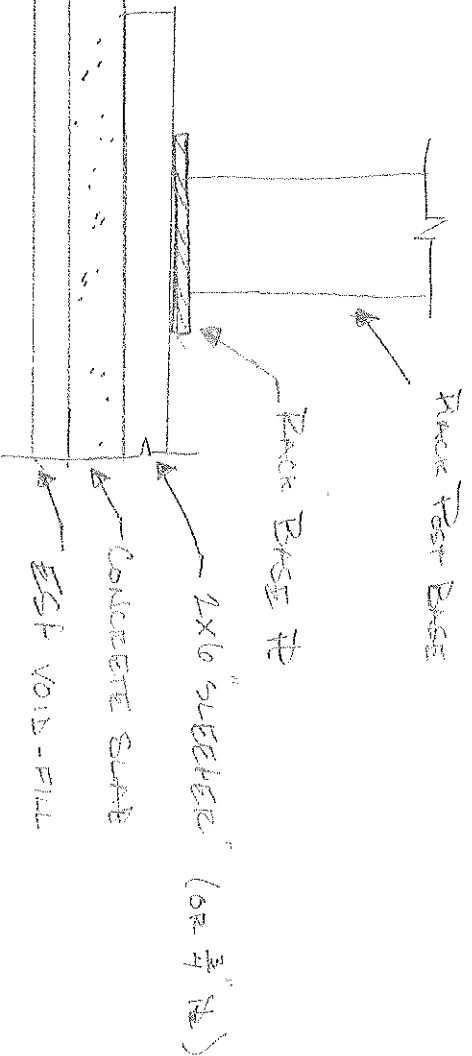
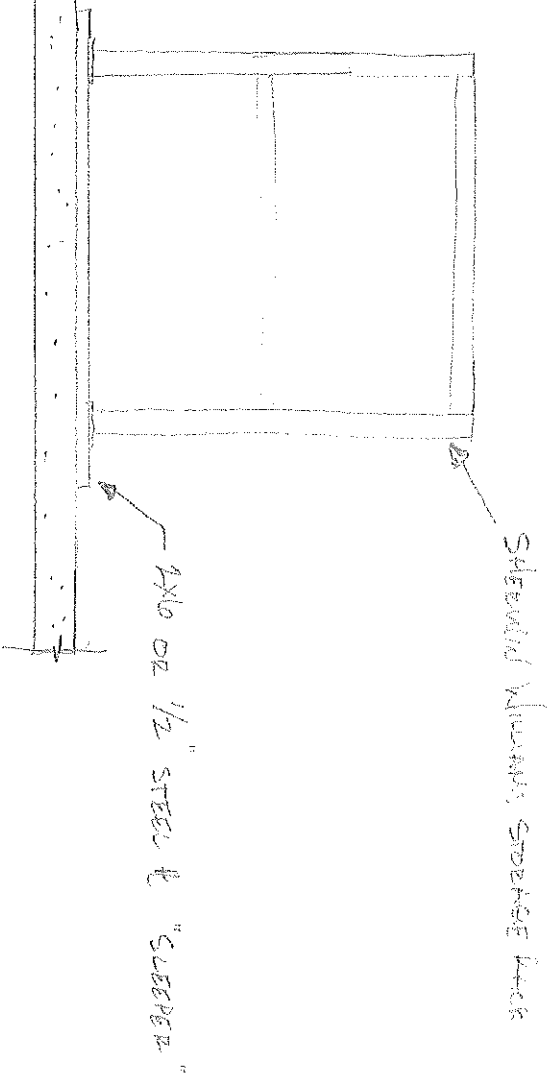

Tometch Engineering, Inc.

10501 Buena Vista Court
Urbandale, Iowa 50322
(515) 280-8022
fax: (515) 727-9124
www.tometchengineering.com

PROJECT JESTER

SHEET NUMBER 4 OF 15

CALCULATED BY KDP DATE 4/20/21

CHECKED BY _____ DATE _____

FILE NUMBER P21-015

JESTER BUILDING

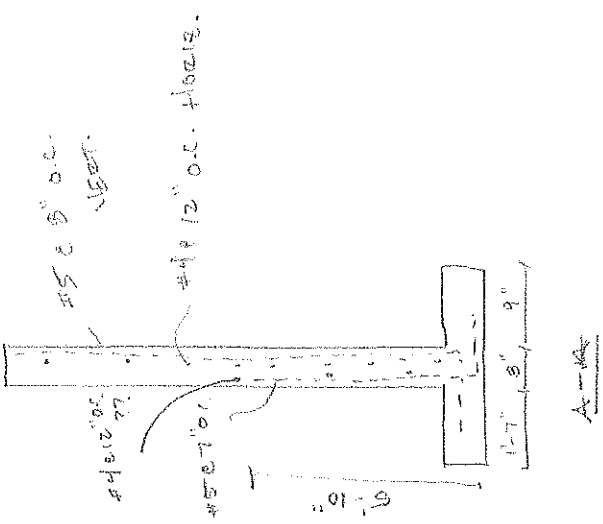
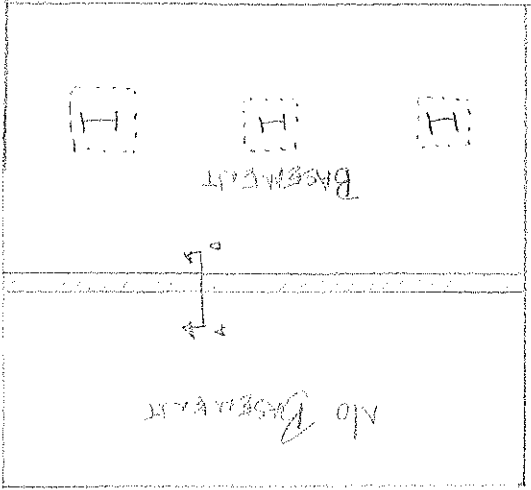

FRAMING / FOUNDATION ← NORTH

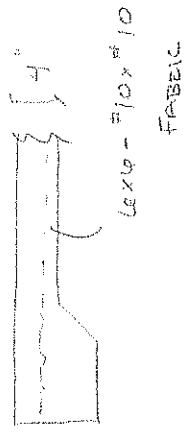
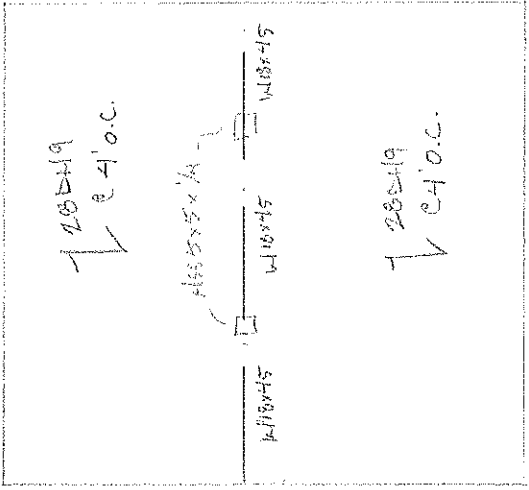

FRAMING / FOUNDATION ← NORTH

CENTER STORAGE DETAILS:

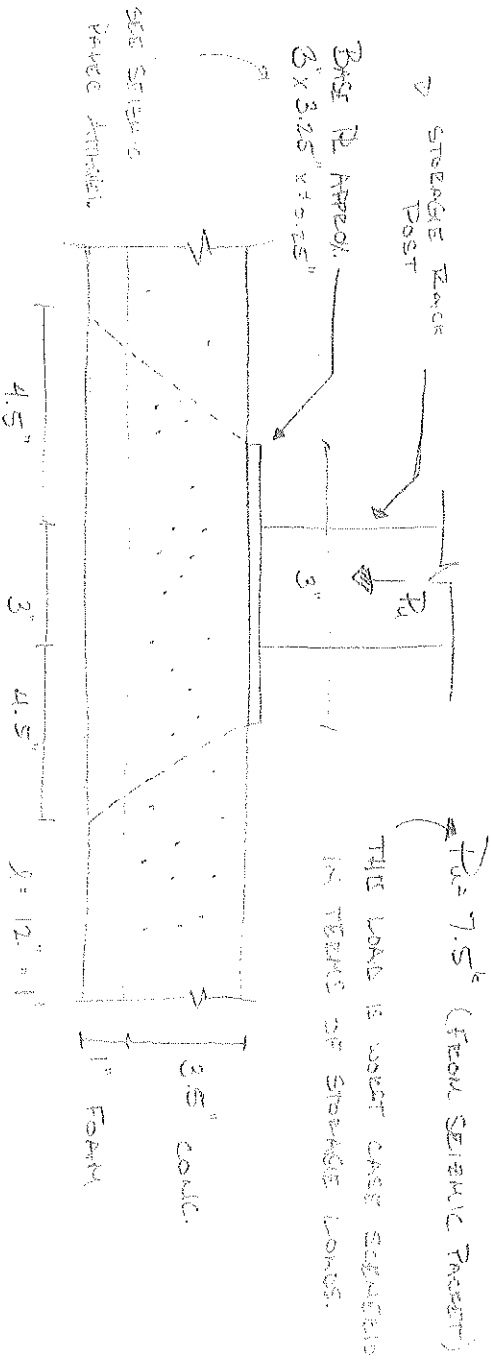

BUCKLING SHEAR:

NO SHEAR REINFORCEMENT: $V_c = 4A \sqrt{f'_c} b_o d$; $b_o = 12 \frac{1}{2} \times 12 \frac{1}{2} = 156 \text{ in}^2$
 $d = 2.5 \text{ ft}$

$V_c = 4(15) \sqrt{3000 \text{ psi}} (48 \text{ in}) (2.5 \text{ ft}) = 25290.7 \text{ lb}$

$\phi = 0.75 \therefore \phi V_c = 19718 \text{ lb} = 19.7 \text{ k} \rightarrow P_u = 7.5 \text{ k}$

•• SAME RESISTS ANOTHER SHEAR

SPACING CAPACITY:

$7.5 \text{ k} / 1.44 = 5.2 \text{ k (kips)}; 5200 \text{ lb} / 15 \text{ ft} = 350 \text{ lb/ft}$

ESP w/ 90 psi COMPRESSIVE STRENGTH: $90 \text{ lb/in}^2 \times 144 \text{ in}^2 / \text{ft}^2 = 12960 \text{ lb/ft} \rightarrow 7500 \text{ lb/ft}$

OK

Tometich Engineering, Inc.

10501 Buena Vista Court
Urbandale, Iowa 50322
(515) 280-8022

fax: (515) 727-9124
www.tometichengineering.com

PROJECT JESTEE

SHEET NUMBER 0 OF 15

CALCULATED BY KDP DATE 4/20/21

CHECKED BY _____ DATE _____

FILE NUMBER P21-0105

JESTEE - SLAB ANALYSIS w/ FORKLIFT

- 1200# CAPACITY (KSD)
- 1500# WEIGHT (UNLOADED) } $P_{max} = 4700 \# \times 1.4 = 6580 \#$ (ULT.)
- 10.5' x 5' RUBBER TIRES

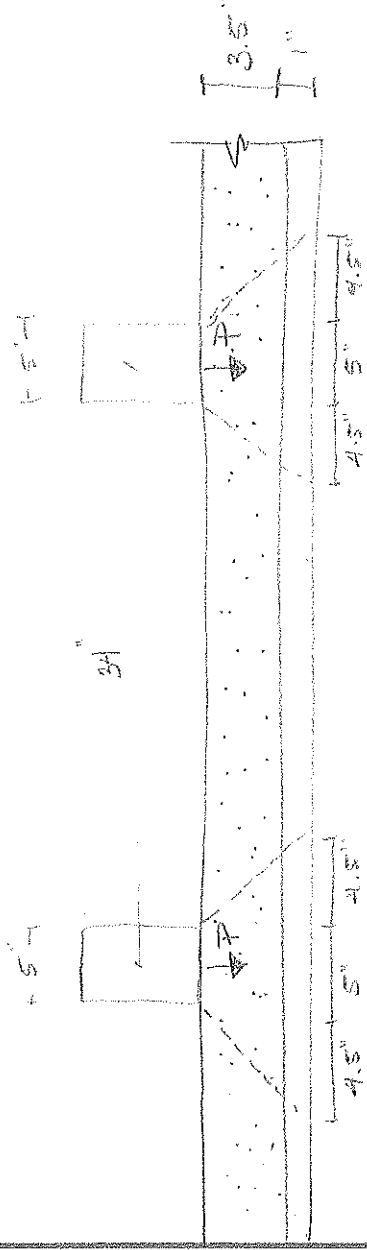

RUCKLING SHEAR:

No SLURF RUCKLING: $\phi V_c = 19716 \#$ (SEE PREVIOUS PAGE) $> 6580 \#$!! OK

BEARING CAPACITY: $\frac{4700 \#}{(4.5' + 5' + 4.5') \times 12'}$

$= 27.97 \text{ ksi} = 4028.6 \text{ PSF}$
BEARING PRESSURE

ALLOWABLE BEARING $= 90 \# / \text{in}^2 \times 144 \text{ in}^2 / \text{ft}^2 = 12960 \# / \text{SF}$

$4028 \text{ PSF} < 12960 \# / \text{SF}$

∴ OK



7/15

Concrete Stabilization Technologies, Inc.
 8500 East Warren Ave.
 Denver CO 80231
 303-306-9191 WWW.CSTSTABILIZATION.COM

POUR-IN-PLACE SYSTEM CST-003

DESCRIPTION:

CST-003 is a hydrophobic, two-component, HFC 245fa blown, all PMDI-based, pour-in -place urethane foam system designed for concrete jacking and cavity filling in wet environments. CST-003 has low component viscosities making the system suitable for mechanical mix machines, high pressure (over 600 psi) impingement mixing machines or hand mixing.

DISTINGUISHING CHARACTERISTICS:

- Excellent Lifting Capacity
- Good Performance in Wet Environments
- Excellent Compressive Strength
- Good Dimensional Stability

TYPICAL RESIN PROPERTIES:

Viscosity @ 72°F	24-003 R 475 cps	24-003 A 200 cps
Lbs./Gallon	8.9 lbs.	10.2 lbs.
Appearance	opaque, black liquid	transparent, brown liquid
Shelf Life	6 months	6 months

MIX RATIO:

	24-003 R	24-003 A
By Weight	100 parts	116 parts
By Volume	100 parts	100 parts

TYPICAL REACTION PROPERTIES:

	Hand Mix @ 72°F	Machine Mix @ 120°F
Cream Time (sec)	20	7
Gel Time (sec)	47	
Tack Free Time (sec)	51	14
Rise Time (sec)	90	15
Density (FRC)	4 pcf	3 - 4 pcf

TYPICAL PHYSICAL PROPERTIES:

Restrained Core Density, ASTM D1622	5.5 pcf
Compressive Strength, ASTM D1621	90 psi
Tensile Strength, ASTM D1623	110 psi
Closed Cell Content, TM 300	>94%
Water Absorption, ASTM D2842	≤0.04 lbs/sq ft
Dimensional Stability, ASTM D2126	Volume change
Heat age, 200°F, 28 days	-1.5%
Humid age, 158°F, 100% R.H., 28 days	-1.0%
Cold age, -20°F, 28 days	-0.1%
Resistance to Solvents	Excellent
Resistance to Mold and Mildew	Excellent
Maximum Service Temperature	200°F

*The above values are average values obtained from laboratory experiments and should serve only as guide lines.

8/15

CST-003 APPLICATION INFORMATION

EQUIPMENT AND COMPONENT RATIOS:

CST-003 should be mixed by pour machines designed to mix urethane chemicals. It is recommended that this system be processed with a Gusmer/Graco 20/35 with a GX-7 gun. Preheats and hose heats may be set in the temperature range of 100-140°F depending on ambient conditions. Use a #16160-125-A2 pour module with no disc. CST-003R is connected to the resin/polyol pumps with CST-003A being connected to the isocyanate pumps.

STORAGE AND USE OF CHEMICALS:

Keep temperature of chemicals at 70°F for several days before use. Cold chemicals can cause poor mixing, pump cavitation or other process problems due to higher viscosity at lower temperatures. Storage temperature should not exceed 100°F. Prolonged exposure to temperatures below 60°F can cause the 'A' component to freeze. Do not store in direct sunlight. Keep drums tightly closed when not in use and under nitrogen pressure of 2 - 3 psi after they have been opened.

SAFE HANDLING OF LIQUID COMPONENTS:

Use caution in removing bungs from the container. Loosen the small bung first and let any built up gas escape before completely removing. Avoid prolonged breathing of vapors. In case of chemical contact with

eyes, flush with water for at least 15 minutes and get medical attention. For further information refer to "MDI-Based Polyurethane Foam Systems: Guidelines for Safe Handling and Disposal" publication AX-119 published by the Center For The Polyurethanes Industry 1300 Wilson Blvd, Suite 800, Arlington, VA 22209.

Caution:



Tomelich Engineering, Inc.
consulting structural engineers
Tomelich Engineering
10501 Beuna Vista Court
Urbandale, IA

Project
Jester - 4508 Douglas

Job Ref.
P21-065

10/15

Section
Basement Wall

Sheet no./rev.
1

Calc. by
KDP

Date
3/30/2021

Date

App'd by

Date

RETAINING WALL ANALYSIS

In accordance with International Building Code 2015

Tedds calculation version 2.9.08

Retaining wall details

Stem type Propped cantilever

Stem height $h_{stem} = 10$ ft

Prop height $h_{prop} = 10$ ft

Stem thickness $t_{stem} = 8$ in

Angle to rear face of stem $\alpha = 90$ deg

Stem density $\gamma_{stem} = 150$ pcf

Toe length $l_{oe} = 0.75$ ft

Heel length $l_{heel} = 1.583$ ft

Base thickness $t_{base} = 12$ in

Base density $\gamma_{base} = 150$ pcf

Height of retained soil $h_{ret} = 10$ ft

Angle of soil surface $\beta = 0$ deg

Depth of cover $d_{cover} = 0$ ft

Retained soil properties

Soil type Medium dense well graded sand

Moist density $\gamma_{mr} = 135$ pcf

Saturated density $\gamma_{sr} = 145$ pcf

Effective angle of internal resistance $\phi_r = 30$ deg

Effective wall friction angle $\delta_r = 0$ deg

Base soil properties

Soil type Medium dense well graded sand

Soil density $\gamma_b = 115$ pcf

Cohesion $c_b = 0$ psf

Effective angle of internal resistance $\phi_b = 30$ deg

Effective wall friction angle $\delta_b = 15$ deg

Effective base friction angle $\delta_{bb} = 30$ deg

Allowable bearing pressure $P_{bearing} = 2000$ psf

Loading details

Dead surcharge load

Live surcharge load

Surcharge = 250 psf
Surcharge = 200 psf → FORKLIFT + WORKERS

↑ STORAGE



Tomelich Engineering, Inc.
consulting structural engineers
Tomelich Engineering
10501 Beama Vista Court
Urbandale, IA

Project
Jester - 4508 Douglas

Job Ref.
P21-065

12/15

Section
Basement Wall

Sheet no./rev.
3

Calc. by
KDP

Date
3/30/2021

Chk'd by

App'd by

Date

From IBC 2015 cl.1807.2.3 Safety factor

Load combination 1

1.0 x Dead + 1.0 x Live + 1.0 x Lateral earth

Bearing pressure check

Vertical forces on wall

Wall stem

$$F_{stem} = A_{stem} \times \gamma_{stem} = 1000 \text{ plf}$$

Wall base

$$F_{base} = A_{base} \times \gamma_{base} = 450 \text{ plf}$$

Surcharge load

$$F_{sur,v} = (\text{Surcharged} + \text{Surcharge}_L) \times l_{heel} = 728 \text{ plf}$$

Moist retained soil

$$F_{moist,y} = A_{moist} \times \gamma_{mr} = 2137 \text{ plf}$$

Total

$$F_{total,y} = F_{stem} + F_{base} + F_{sur,v} + F_{moist,y} = 4316 \text{ plf}$$

Horizontal forces on wall

Surcharge load

$$F_{sur,h} = K_A \times (\text{Surcharged} + \text{Surcharge}_L) \times h_{eff} = 1687 \text{ plf}$$

Moist retained soil

$$F_{moist,h} = K_A \times \gamma_{mr} \times h_{eff}^2 / 2 = 2723 \text{ plf}$$

Base soil

$$F_{pass,h} = -K_p \cos(\delta_b) \times \gamma_b \times (d_{cover} + h_{base})^2 / 2 = -276 \text{ plf}$$

Total

$$F_{total,h} = F_{sur,h} + F_{moist,h} + F_{pass,h} = 4133 \text{ plf}$$

Moments on wall

Wall stem

$$M_{stem} = F_{stem} \times X_{stem} = 1083 \text{ lb_ft/ft}$$

Wall base

$$M_{base} = F_{base} \times X_{base} = 675 \text{ lb_ft/ft}$$

Surcharge load

$$M_{sur} = F_{sur,v} \times X_{sur,v} - F_{sur,h} \times X_{sur,h} = -7668 \text{ lb_ft/ft}$$

Moist retained soil

$$M_{moist} = F_{moist,y} \times X_{moist,y} - F_{moist,h} \times X_{moist,h} = -5262 \text{ lb_ft/ft}$$

Base soil

$$M_{pass} = -F_{pass,h} \times X_{pass,h} = 92 \text{ lb_ft/ft}$$

Total

$$M_{total} = M_{stem} + M_{base} + M_{sur} + M_{moist} + M_{pass} = -11080 \text{ lb_ft/ft}$$

Check bearing pressure

Maximum friction force

$$F_{friction_max} = F_{total,y} \times \tan(\delta_{ub}) = 2492 \text{ plf}$$

Propping force

$$F_{prop_stem} = \max((F_{total,y} \times l_{base} / 2 - M_{total}) / (h_{prop} + l_{base}), F_{total,h} - F_{friction_max}) = 1641 \text{ plf}$$

Moment from propping force

$$M_{prop} = F_{prop_stem} \times (h_{prop} + l_{base}) = 18051 \text{ lb_ft/ft}$$

Distance to reaction

$$\bar{x} = (M_{total} + M_{prop}) / F_{total,y} = 1.615 \text{ ft}$$

Eccentricity of reaction

$$e = \bar{x} - l_{base} / 2 = 0.115 \text{ ft}$$

Loaded length of base

$$l_{load} = l_{base} = 3 \text{ ft}$$

Bearing pressure at toe

$$q_{toe} = F_{total,y} / l_{base} \times (1 - 6 \times e / l_{base}) = 1107 \text{ psf}$$

Bearing pressure at heel

$$q_{heel} = F_{total,y} / l_{base} \times (1 + 6 \times e / l_{base}) = 1770 \text{ psf}$$

Factor of safety

$$FOS_{bp} = P_{bearing} / \max(q_{toe}, q_{heel}) = 1.13$$

PASS - Allowable bearing pressure exceeds maximum applied bearing pressure



80

13/15



CAPACITY
2200 pounds at 24" load center.

BATTERY
24-volt, lead-acid industrial battery. Minimum battery weight is 290 pounds. Will accept batteries from 150 A. H. to 350 A. H. capacity. Battery compartment dimension is 32.3" x 9.0" x open height. Connector is SB-175 red with 20" leads in position "B."

SPEED
Travel
Variable from 0 mph to 3.3 mph Empty Loaded
Variable from 0 mph to 2.9 mph

Lifting
49 ipm Empty Loaded
32 ipm

Lowering
42 ipm Empty Loaded
60 ipm

WEIGHT
Approximately 2500 pounds, less battery.

TIRES
Drive 10.5" x 5" Rubber
Outriggers 4" x 2.875" Tandem Polyurethane

MAST
Heavy-duty, interlocking I-beam operating on certified ball bearing rollers. Modular design bolted to chassis for easy mounting.

FORK GARBIAGE
ITA Class II, hook-type, 30" wide with 48" high load backrest.

HYDRAULIC SYSTEM
Electric lift/lower controls in handle with pressure compensated valve for constant lowering in all conditions. Manual lift and lowering control valve for precise pallet placement. Heavy-duty pump and motor are conveniently located for easy access during routine maintenance checks. Pressure overhauled relief valve and lowering control fuses.

ELECTRICAL
State-of-the-art transistor controller requires no connectors to control separately excited drive motor. Ininitely variable speed control with class "F" insulated motor. Emergency power cutoff switch. Line contactor to protect against reverse polarity.

TRANSISTOR CONTROLLER
Drive motor controller is fully programmable with service tool handset. Power On Self Test

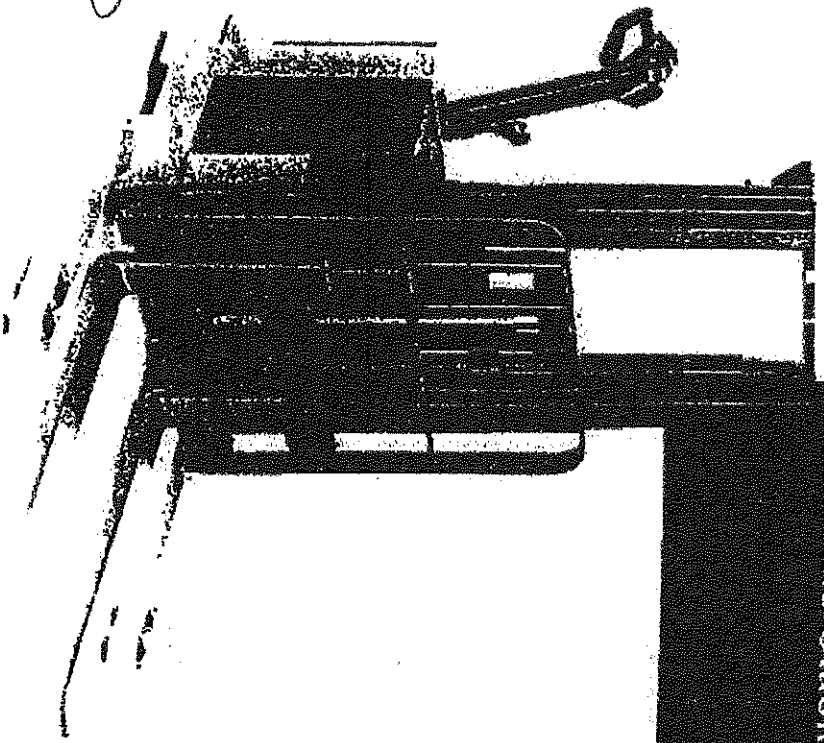

and run-time diagnostics provide exceptional reliability. Complete diagnostics can be performed with service tool handset.

OPERATOR CONTROLS
Travel speed and direction controlled by ergonomically correct handle and operable with either hand. Electric lift and lower control buttons in handle with horn button and reversing switch. Manual lift and lower controls on console. Thumb-control travel is standard.

TRANSMISSION
Double reduction 22 to 1 gear ratio with helical and spur-cut gears for quiet operation and smooth power transfer. Single piece cast transmission housing with tapered roller bearings on final drive running in oil bath. Intermediate gear operates on ball bearings.

BRAKE
Drum brake is mounted on drive motor armature shaft to greatly multiply braking power through the double-reduction transmission.

STANDARD EQUIPMENT
■ Transistor Motor Controller With Separately Excited Drive Motor
■ UL "E" Rating
■ Thumb Control
■ Key Switch
■ Horn

■ Electric Raise And Lower Controls
■ Manual Raise And Lower Controls
■ 48" High Load Backrest
OPTIONAL EQUIPMENT
■ UL "EE" Rating
■ Drive Tire Compounds
■ Twist Grip In Place Of Thumb Control
■ Toggle Switch In Place Of Key Switch
■ Hour Meter
■ Hour Meter/BDI Combination Gauge
■ Lift Interrupt
■ Warning Light
■ Corrosion Conditioning
■ Cold Storage Conditioning
■ Audible Travel Alarm
■ Battery Compartment Rollers

14/15

WSX22

Electric Walkie Straddle Stacker

SPECIFICATIONS

MAST SELECTION		Mast Overall Length (ft)	Mast Load Capacity (lb)	Mast Overall Height (ft)	Mast Overall Width (ft)	Mast Overall Weight (lb)
2-Stage	3-Stage					
104"	71"	12'	32'	290		
128"	83"	12'	32'	290		
152"	95"	12'	32'	300		
190"	111"	93"	32'	300		

Mast capacity is 2200 pounds at 2' load center. Actual capacity is dependent upon specific track configuration. Contact factory for further information.

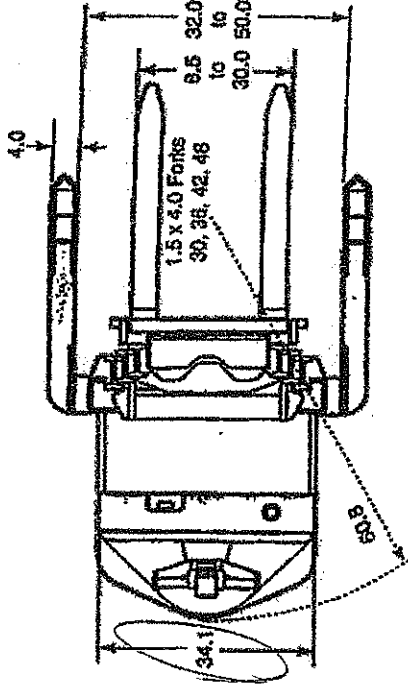

MAST WIDTH REQUIREMENTS FOR RIGHT-ANGLE STACKING

Load (lb)	Mast Length	
	48"	68"
30	74"	87"
32	74"	82"
38	73"	82"
40	72"	81"
42	71"	81"
48	69"	80"

Mast width requirements based on 5' clearance between pallets. Add 9", 10" for ease of operation. Add 6" for 3-stage mast.

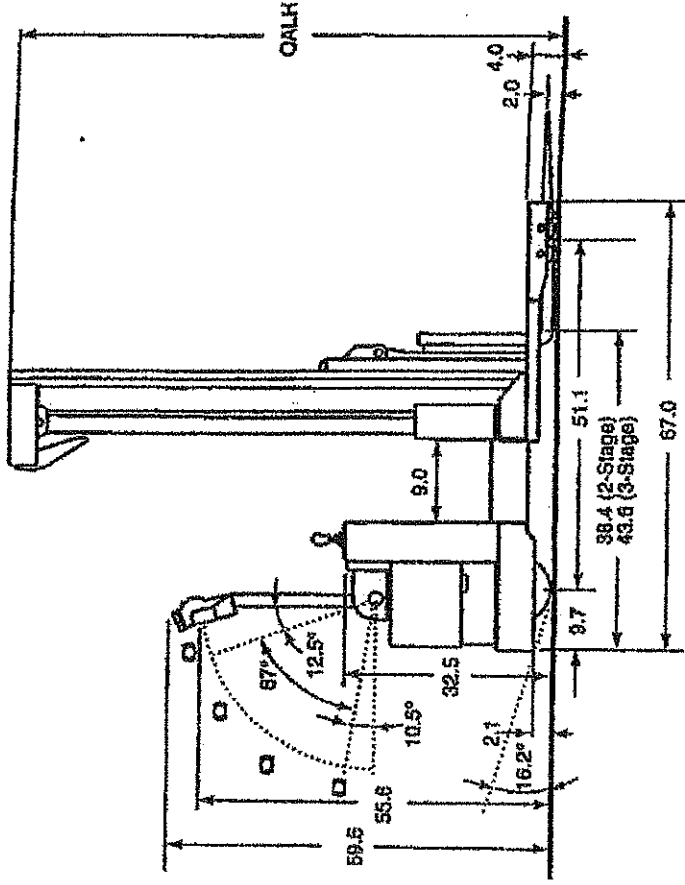

OSHA requires strict written approval from factory for modifications that affect capacity and safe operation.

DISTRIBUTED BY

BT Prime-Mover, Inc.
3305 North Highway 38
Muscatine, Iowa 52761-6800
Phone: 43191 262-7700
Fax: (319) 262-7500

3" Fork-Mover Inc. reserves the right to change specifications without notice and without incurring any responsibility related to such changes.
Printed in U.S.A. 4-97-84 Doc# 983597

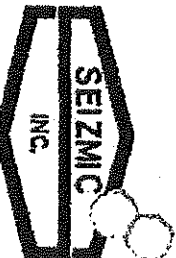

MATERIAL HANDLING ENGINEERING
 TEL: (909)869-0989 • FAX: (909)869-0981
 161 ATLANTIC STREET • POMONA • CA 91768

PROJECT SHERWIN WILLIAMS
 FOR SHERWIN WILLIAMS
 SHEET NO. 14 OF 14
 CALCULATED BY BOB S. DATE 07-03-1997

SLAB AND SOIL TYPE 1

THE SLAB IS CHECKED FOR PUNCTURE STRESS. IF NO PUNCTURE OCCURS, IT WILL BE ASSUMED TO
 DISTRIBUTE THE LOAD OVER A LARGER AREA OF SOIL AND HENCE, WILL ACT AS A FOOTING.

(a) PUNCTURE

Pmax = 1.4 DEAD LOAD + 1.7 LIVE LOAD
Pmax = 1.4 * Pcol + 1.7 * (Mot/d)
 = 7,528 lb.

INCLUDES OVERHEAD MOMENT
 FORCES; CONSIDERABLE FOR (A, B or
 POSSIBLE (FOOTING BOLDS, etc))

$F_{punct} = 2 * \sqrt{f'_c} = 126.5 \text{ psi.}$

$A_{punct} = [(w+t/2)+(d+t/2)]^2 * t = 147.0 \text{ in.}^2$

$f_v/F_v = P_{max}/(A_{punct} * F_{punct}) = 0.40$

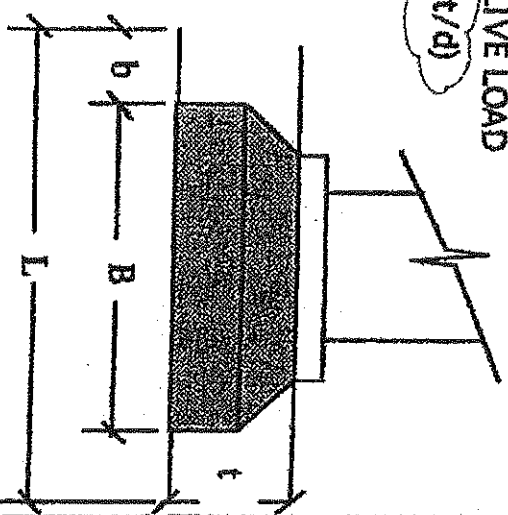

(b) SLAB TENSION

$A_{soil} = P_{max}/(1.33 * f_{soil}) = 5.65 \text{ ft.}^2$
 = 813 in.²

$L = \sqrt{A_{soil}} = 28.5 \text{ in.}$

$B = \sqrt{L * d} + t = 9.1 \text{ in.}$

$b = (L-B)/2 = 9.7 \text{ in.}$

$M_{conc} = w * b^2 / 2 = (1.33 * f_{soil} * b^2) / (1.44 * 2)$
 = 435.2 in.lb.

$S_{conc} = 1 * t^2 / 6 = 6.00 \text{ in.}^3$

$F_{conc} = 50 * \sqrt{f'_c} = 284.60 \text{ psi.}$

$f_b/F_b = M_{conc} / (S_{conc} * F_{conc}) = 0.25$

BASE PLATE
 w = 3.25 in.
 d = 3 in.

CONCRETE
 t = 6 in.

SOIL
 f_s = 1000 psf.