



# V. DISTRICTS, LAND USE, AND DEVELOPMENT STANDARDS

## INTRODUCTION

When taken together land uses and development standards, along with design guidelines for public and private properties, form a complete set of policies that will steer future development for the individual Districts within the Specific Plan area. Permitted land uses and development standards are regulatory tools for guiding development and redevelopment in the Specific Plan area and are detailed in this chapter, while design guidelines for the private realm are presented in Chapter IV (Architectural Design Guidelines) and design guidelines for the public realm are presented in Chapter VI (Streetscape Beautification and Public Improvements.) The land use and development standards presented here will help guide change toward achieving the overall Downtown vision, and, more specifically, will provide refined direction for the types of uses that should occur and how these uses will be allowed to develop in each area of the Downtown. In concert with the design guidelines, the land use and development standards are intended to reinforce the desired urban image in the study area. These standards are also intended to improve the overall aesthetic appearance and to serve as an incentive for private reinvestment in Downtown.

## DISTRICT-BASED APPROACH

A typical zoning ordinance is organized around zoning districts for specific land use types, i.e. commercial retail, service, residential, office, etc., and is further regulated by the development standards that apply to those specific set of uses. However, this single-use, or Euclidean, approach of separating uses often creates barriers to developing an inviting, pedestrian-friendly realm, despite the use of various overlays and other methods to minimize its Euclidian nature. Therefore, this document presents a mixed-use zoning approach in order to reestablish the Downtown as a focal point of activity, as advocated by the General Plan, and to meet the goals envisioned by the community and described in Chapter III (Vision).

In contrast to the single-use zoning based on land use type, the Specific Plan is based on geographic areas called planning districts. In the district approach, each District has a unique vision and a tailored range of uses and development standards that support the desired future condition. The district-based approach is by nature a “mixed-use” zoning approach where the desired activities and building forms dictate what is and is not allowed.

The Specific Plan divides the Downtown area into six Districts. Each District has a particular vision for future development. Land use and development standards, as well as design guidelines, will give direction for each area of the Downtown to help each section achieve the future state envisioned by the community. The six Districts are as follows:

- Downtown Historic District
- Downtown Expansion District
- Civic/Cultural Arts District
- Transition District
- Cannery District
- Gateway District



# Land Use

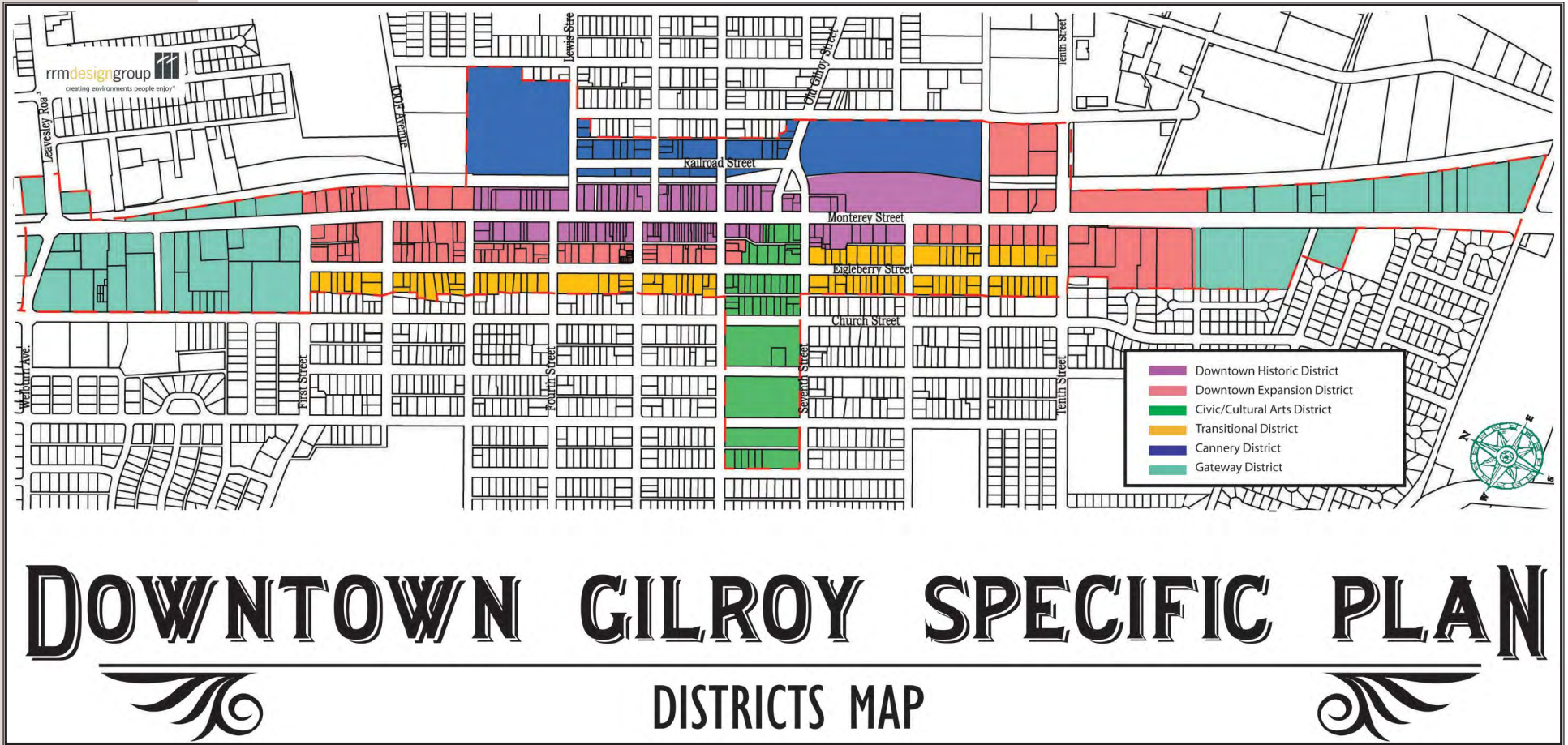

# DOWNTOWN GILROY SPECIFIC PLAN

## DISTRICTS MAP

FIGURE 5.1 - DISTRICTS MAP



## USING THIS CHAPTER

Within this chapter, a Permitted Uses Table designates the permitted, conditionally permitted, and prohibited land uses within each District of the Specific Plan area. Before new development occurs, this section of the chapter must be consulted to determine whether a specific land use is allowed in a specific District.

In addition to regulating the type of land uses allowed, development is further regulated by specific site development standards that are critical to the performance of each use, i.e. building height for each of the six districts, massing, setback, build-to lines, relationship to street and sidewalk, required parking, location of parking, etc. In this chapter, these standards are presented by District. In addition to the regulated land use and development standards provisions of this Specific Plan, future development is also directed by design guidelines that provide guidance on a range of site, landscape, and building issues and concepts. While all projects must adhere to the guidelines presented in Chapter IV (Architectural Design Guidelines), additional architectural design guidelines specific only to a particular District may be provided in this chapter within the District sections, following the land use and development standards for the District. Before new development occurs, the appropriate District section of this chapter must be consulted to determine appropriate development standards and supplemental design guidelines for the District.





### PROJECTED BUILD-OUT

As part of the Specific Plan process, a projected build-out analysis was conducted for environmental and traffic analysis purposes. The following table summarizes the results of the analysis and reflects a theoretical build-out maximum for the Specific Plan, which has a twenty year life from 2005-2025. It was generated with generalized assumptions and does not take into account environmental constraints or application of all development standards on each specific parcel.

Recommended Buildout Assumption					Buildout %						
							Undeveloped %	Developed %			
							60%	10%			
(60% of undeveloped property will buildout and 10% of developed properties will increase in size)											
	Existing Development (sq ft)	Proposed FAR	Estimated Commercial Development %	Estimated Residential Development %	Commercial Buildout on Undeveloped Properties (sq ft)	Residential Buildout on Undeveloped Properties (dwelling units)	Estimated Additional Commercial Buildout on Developed Properties (sq ft)	Additional Residential Units on Developed Properties (dwelling units)	Commercial Buildout (sq ft)	Residential Dwelling Units	New Parking spaces (assume 3 per 1000 sq ft + 1.75 per dwelling unit)
Historic	459,646	2.50	44%	56%	31,617	50	41,122	65	72,738	116	421
Expansion	527,208	2.50	44%	56%	154,399	246	127,095	202			
Cannery	79,372	2.00	29%	71%	171,185	524	9,724	30	180,909	554	1512
Cannery project	202,000	2.00	29%	71%	45,000	206	0	0			
Transitional	259,549	1.50	69%	31%	78,552	44	62,714	35	141,266	79	563
Civic/residential only	42,508	1.50	40%	60%	0	0	7,322	14			
Gateway	199,155	0.75	73%	27%	213,443	135	52,322	24			
<b>Total</b>	<b>1,769,438</b>				<b>694,197</b>	<b>1,205</b>	<b>300,298</b>	<b>371</b>	<b>394,914</b>	<b>749</b>	<b>2,495</b>
							Commercial (sq. ft.)	Residential (dwelling units)			
							<b>994,495</b>	<b>1,576</b>			
					Total New Construction (20 year plan)=						

TABLE 5.1 - RECOMMENDED BUILDOUT ASSUMPTION

Please note the above table does not apply to parcels that are not likely to transition within the next 20 years, such as the Catholic church and school, the Civic and Cultural Arts centers, the Cannery Project, and lots slated for future public parking.



## PERMITTED USES TABLE

The Permitted Use Table indicates whether a variety of uses are unconditionally permitted (designated with an X), permitted only with a conditional use permit from the Planning Commission (designated with a C), or permitted only as a temporary use (designated with a T). Where no symbol is shown, the use is prohibited. The Planning Commission or its designee shall determine, upon written request, whether or not any use not listed in the Permitted Uses Table is similar in character to a described use for the purpose of applying the District regulations and conditions.

X = Unconditionally permitted T = Temporary Use C = Permitted only with Conditional Use Permit granted by Planning Commission	Downtown Historic District	Downtown Expansion District	Civic/Cultural Arts District	Transitional District	Cannery District	Gateway District
<b>Commercial Uses</b>						
Animal Boarding		X <sup>11</sup>		X <sup>11</sup>	X <sup>11</sup>	C
Animal Grooming <sup>XXX</sup>						
Animal Hospital/Veterinary Office						X
Antique Shop <sup>XXXX</sup>						
Appliance Repair <sup>XXX</sup>						
Arcade and Internet Access as primary use <sup>XXXX</sup>						
Art, Dance, Gymnastic, and Music Studios or Galleries	X <sup>3</sup>	XXXXX				
Art, Handicraft					XX	
Auction House	X <sup>4</sup>	XX				
Automotive Body Repair & Painting						C
Automotive Parts Sales		X <sup>10</sup>				X
Automotive Repair and Service		X <sup>10</sup>				X <sup>13</sup>
Automotive Sales	X <sup>9</sup>	XX				
Automotive Sales, Temporary <sup>3</sup>		CC			CC	

TABLE 5.2 - PERMITTED USES TABLE - REVISED MAY 21, 2012



Land Use

X = Unconditionally permitted T = Temporary Use C = Permitted only with Conditional Use Permit granted by Planning Commission	Downtown Historic District	Downtown Expansion District	Civic/Cultural Arts District	Transitional District	Cannery District	Gateway District
Automotive Car Wash						X
Automotive Gasoline Station		X <sup>10</sup>				X
Automotive Tire Shop		X <sup>10</sup>				X
BankXXXXX						
Bakery/Coffee House	XXXXXX					
Bakery, Commercial	C <sup>12</sup>	C <sup>12</sup>			XX	
Bed and Breakfast EstablishmentXXX						
Boat and Motorcycle SalesXX						
Bowling AlleyXXX						
Building Materials Sales and Storage						X
Card RoomCC						
Clothing Sales/ Service EstablishmentXXXXX						
Cottage industry with light manufacturing and assembly					XX	
Dance Venue, Small	XXXXXX					
Dance Venue, Medium <sup>14</sup>	XXXXXX					
Dance Venue, Large	X <sup>15</sup>	X <sup>15</sup>	X <sup>15</sup>			C <sup>14</sup>
Desktop Publishing/Copy Shop	X <sup>4</sup>	XXXXX				
FestivalTTTTT						
Grocery Store or Deli (Not supermarket)	XXXXXX					
Gymnasium/Health Studio	XXXXXX					
Home Occupation <sup>6</sup>	XXXXXX					
Hotel, MotelCXX						
Laboratory (Research and Testing)	X <sup>4</sup>	CC				X

TABLE 5.2 - PERMITTED USES TABLE - REVISED MAY 21, 2012





X = Unconditionally permitted T = Temporary Use C = Permitted only with Conditional Use Permit granted by Planning Commission	Downtown Historic District	Downtown Expansion District	Civic/Cultural Arts District	Transitional District	Cannery District	Gateway District
Landscape Nursery						X
Liquor Sales/Bars (On site consumption) <sup>5</sup>	C <sup>1</sup>	X		C <sup>1</sup>	C <sup>1</sup>	X
Liquor Sales (Off site consumption) <sup>5</sup>	CX			C		X
Liquor Sales with Tasting <sup>5</sup> (Wine and Beer only)	CXXXX					
Medical or Dental Office/Clinic	X <sup>4</sup>	XXX				
Mortuary or Crematory	CXX					
Newspaper Printing Facility						X
Office	X <sup>4</sup>	XXXXX				
Outdoor Amusement/ Recreation						C
Parking Lot (Automobile Parking)	XXXXXX					
Pawn Shop	XX					
Personal Services <sup>7</sup>	X <sup>8</sup>	XXXXX				
Pool & Billiards Establishment	XXC					
Printing/ Sign Painting Establishment	XXXXX					
Restaurant	XXXXXX					
Restaurant with drive through	XX					
Retail Sales 10,000 sq. ft. or less	XXXXX					
Retail Sales 10,001 sq. ft. to 50,000 sq. ft.	XX					
Retail Sales 50,001 sq. ft. or more						X
Supermarket	XX					
Theater	XXXXXX					

TABLE 5.2 - PERMITTED USES TABLE - REVISED MAY 21, 2012



X = Unconditionally permitted T = Temporary Use C = Permitted only with Conditional Use Permit granted by Planning Commission	Downtown Historic District	Downtown Expansion District	Civic/Cultural Arts District	Transitional District	Cannery District	Gateway District
<b>Public &amp; Semi-Public Uses</b>						
Ambulance Service		X <sup>10</sup>				X
Community Center	X <sup>4</sup>	XXXXX				
Day Care Center <sup>C</sup>			XXXX			
Hospital, Rest Home, Sanitarium <sup>CX</sup>						
Lodge, Club, or Fraternal Hall	X <sup>4</sup>	CX			C	X
Public Facility	XXXXXX					
Religious Institution	X <sup>4</sup>	X		XXX		
School (Private ≤ 12 Students)	X <sup>4</sup>	XXXXX				
School (Private > 12 Students)	CCCCCC					
<b>Residential Uses</b>						
Boarding or Rooming House		C		C	C	
Caretaker's Quarters	XXXXXC					
Residential Units <sup>2</sup>	X <sup>4</sup>	X <sup>4</sup>	XXXX			
<b>Temporary Uses</b>						
Bazaar	TTTTT					
Christmas Tree Lot		T		T	T	T
Outdoor Booth/Sales	TTTTTT					

TABLE 5.2 - PERMITTED USES TABLE - REVISED MAY 21, 2012



## Footnotes to Permitted Uses Table - REVISED MAY 21, 2012

1. The requirement for a Conditional Use Permit does not apply to businesses whose primary use is the preparation and service of food and liquor is served as a clearly ancillary use.
2. Residential units may be allowed in conjunction with an existing business. All residential unit projects within commercial zones shall comply with the following guidelines:
  - a. The number of residential units shall not compromise the quality or character of any existing or proposed businesses located on the same property;
  - b. The number of residential dwellings shall be limited by the availability and provision of off-street parking stalls or as allowed by ordinance;
  - c. All bedrooms proposed for residential use shall meet minimum square footage requirements in compliance with the Uniform Building Code; and
  - d. Open space shall be provided, when feasible.
  - e. Notwithstanding subsections (a) and (b) above, the minimum residential density in the DHD, DED and CD districts shall be 20 units per acre.
3. A Conditional Use Permit may be granted to an auto-related sales business for up to four temporary auto sale events on the same property within one calendar year.
4. These uses are unconditionally permitted on the second story and above. Anytime these uses are proposed for the first floor (sidewalk level), a Conditional Use Permit is required.
5. Requests for new ABC liquor licenses is subject to review and approval of the City's ABC Committee and the Chief of Police.
6. Permitted only if the regulations of Section 40, Home Occupations, of the Zoning Ordinance are met.
7. Commercial uses providing needed services of a personal nature. Personal services generally include barber and beauty shops, nail salons, tanning and spa salons, seamstresses, tailors, shoe repair shops, dry cleaning (except bulk processing plants), and self service laundries.
8. Uses offering the primary personal services of massage, tattoo and/or piercing are prohibited.
9. Indoor only for the display and sales of automobiles with no repair or servicing.
10. Not permitted on any parcel fronting on Egleberry Street or on those parcels that may front a side street on the one-half block west of Gourmet Alley.
11. Day boarding only allowed, no overnight boarding.
12. Must have a prominent ancillary retail outlet or use.



13. Must be approved by a Conditional Use Permit if within 150 feet of a residential use.
  14. Provided that all provisions set forth in Chapter 8 of the Gilroy City Code are satisfied.
  15. Up to three (3) large dance venues are allowed in the DHD- Downtown Historic District, DED- Downtown Expansion District, CCA- Civic /Cultural Arts District, combined, and only located on Monterey Street between 1st Street. and 10th Street. and only with a Downtown Special Use Permit granted by the Community Development Director or designee and provided that all provisions set forth in Chapter 8 of the Gilroy City Code are satisfied.
- City Council approval is required for the fourth (4th) or more large dance venue in the DHD- Downtown Historic District, DED- Downtown Expansion District, CCA- Civic /Cultural Arts District, combined, and only located on Monterey Street between 1st St. and 10th St. and only with a Downtown Special Use Permit granted by the Community Development Director or designee and provided that all provisions set forth in Chapter 8 of the Gilroy City Code are satisfied.



# DOWNTOWN HISTORIC DISTRICT

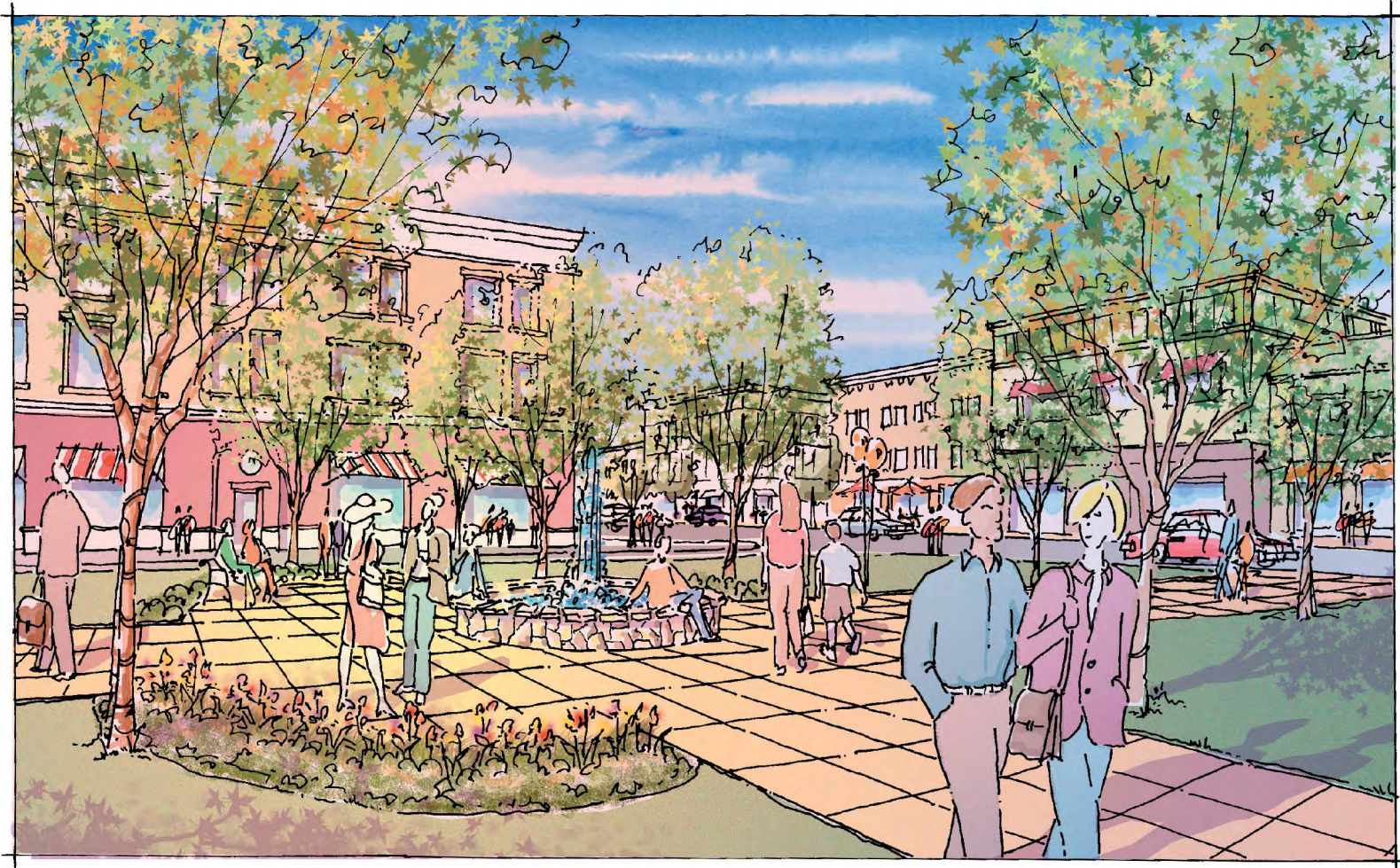

**V LAND USE**



# V

## Land Use

# DOWNTOWN HISTORIC DISTRICT CHARACTER

## VISION



A 24-HOUR ATMOSPHERE SHOULD BE PROVIDED



STREET FRONT RETAIL IS A PRIMARY USE IN THE DOWNTOWN HISTORIC DISTRICT

- Serves as the primary retail and entertainment destination in Downtown
- Provides a 24-hour atmosphere with extended shopping hours with high-quality retail shopping, dining and entertainment activities
- Apartments and offices are located above or behind ground floor retail
- Provides a series of unique outdoor spaces with fountains and public art
- Paseos and plazas create opportunity for a variety of street performers, dances, jazz, farmers' markets, people watching, strolling and other special events
- Wide downtown sidewalks with large landscaped planters, benches, streetlights and strong pedestrian connections to adjacent districts
- Two- to three-story buildings line Monterey Street on either side with restaurants, cafes, and shopping opportunities
- Provides linkages from parking and streets to shops and spaces throughout the commercial areas, with parking located behind commercial
- Architecture reflects historic forms and materials while still allowing complementary contemporary architecture
- Provides youth oriented entertainment uses, such as bowling alleys and arcades
- Provides a multi-cultural experience incorporating adaptive re-use of historic structures

## DESIRED USES\*

- Street front retail with unique atmosphere and street orientation (specialty retail, coffee, bookstore, fine dining, family restaurants, 24-hour gym, small grocery store, art galleries)
- Offices and apartments over retail
- Entertainment (playhouse, theater, arcade, roller or ice skating, cinema, live music venue)
- Selected service uses with high pedestrian activity (travel agency, chamber of commerce) approvable through a conditional use permit

## PROHIBITED USES\*

- Gas and service stations
- Automobile services of all types except indoor automobile displays and sales
- Storage, manufacturing
- Residential at street frontage
- Drive-through restaurants
- Corporate architecture
- Adult stores

\* Refer to Permitted Uses Table for a complete list of uses

# DOWNTOWN HISTORIC DISTRICT STANDARDS

## INTENSITY

### Non Residential and/or Mixed-Use Projects

Max FAR: 2.5 FAR  
 The minimum density for the residential component of mixed use projects is twenty dwelling units per acre.

## SECTION VIEW

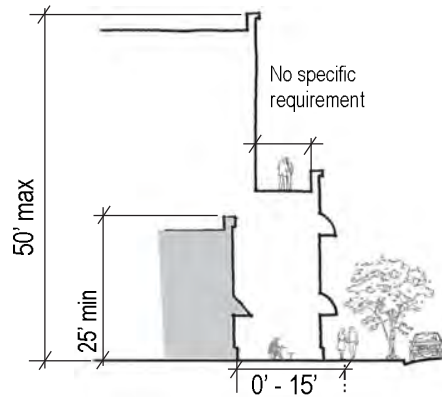

## PLAN VIEW

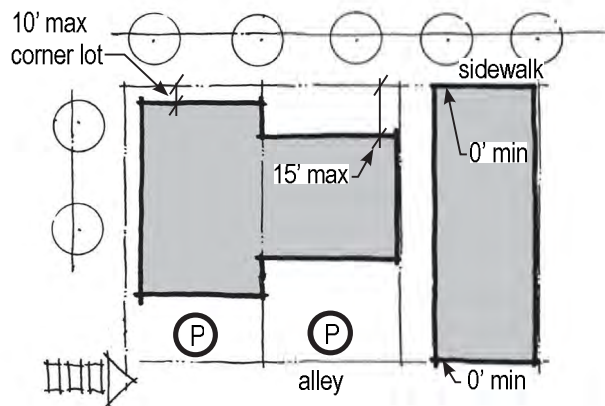

## PRIMARY USES (REFER TO PERMITTED USES TABLE FOR COMPLETE LIST)

### Non Residential

- Retail (coffee, books, art gallery)
- Restaurants (excluding drive-thrus)
- Entertainment (cinema, playhouse)
- Offices (all types, above or behind street front ground floor)

### Residential

- Residential (apartments above street level ground floor)

## URBAN FORM

### Setbacks:

- Front Min: 0' Front Max: 15'
- Side Min: 0' Rear Min: 0'
- Corner Lot Min<sup>2</sup>: 0' Corner Lot Max<sup>2</sup>: 10'
- <sup>1</sup>Parcels East of Monterey Street 51' to accommodate drive access & parking
- <sup>2</sup>Approval dependent on vehicle sight lines

### Building Height:

- Min: 25' at street front
- Max: 50' (3-4 stories)

### Building Form:

- Portions of the third and fourth stories shall be recessed from the front facade
- Buildings with > 40' of linear street frontage shall be designed to replicate traditional 20-40' facade (Refer to Design Guidelines)

Railroad Corridor Standards Apply

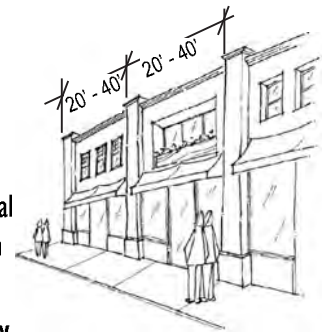

## OFF STREET PARKING

### Parking Location:

Permitted in rear only (except public-owned parking)

### Parking Requirements:\*

- Retail: 1 space/500 sf
- Restaurants: 1 space/6 seats + 1 space/4 shift employees
- Offices: 1 space/400 sf
- Residential units < 800 sf: 1 space/unit + 1 guest space/6 units
- Residential units > 800 sf: 1.5 spaces/unit + 1 guest space/4 units

\* All parking requirements may be satisfied by paying in-lieu fee

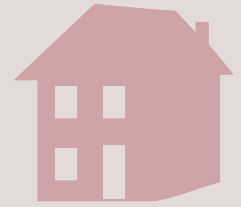

## Urban Form

The buildings in these districts will primarily face sidewalks and paseos. All buildings fronting Monterey Street must maintain a primary entrance and facade on that street. Businesses may operate with a primary entrance off of Gourmet Alley.

Allowable uses are outlined in the Specific Plan Permitted Uses Table with the intent of encouraging pedestrian activity in the Downtown; residential not allowed on the first floor at the street frontage of any building and most office uses are discouraged.

## Front Setbacks

As the Downtown's main thoroughfare, Monterey Street setbacks should aim to create a continuous built edge adjacent to the sidewalk, with slightly varying setbacks to allow for the creation of spaces for outdoor seating areas, outdoor dining, and shopping. These spaces will enrich the pedestrian experience and provide some visual variety within each block.

To help define the corners of street blocks and to create a framework in which the variable setbacks will have an impact on the streetscape, corner buildings shall be located closer to the street. However at no time will a building be allowed to intrude into the minimum corner cutback requirements (refer to the Corner Cutbacks section below).

## Allowable Front Setback Elements

To strengthen the pedestrian experience, allowable uses in the front setbacks include landscaping, retail display areas, and café or outdoor seating areas (so long as seating does not infringe on a seven-foot minimum clear zone of pedestrian passage in the public right of way or obstruct a four-foot minimum clear passage to building entrances).

Parking is not permitted within any front yard setback area or between the building and the street.

## Side Setbacks

To help create a continuous built edge along the streetscape edge and further define the front setback outdoor areas, side setbacks shall be used for pedestrian access on one side of the building only; adjacent properties should share pedestrian access points along common property lines.



## Rear Setbacks

Rear setbacks for parcels west of Monterey Street (along Gourmet Alley) should allow for a “shared space” between pedestrians and vehicles, acting as both a paseo system as well as retaining functionality for vehicle access, utility services, commercial loading, and spaces for employee parking.

Parcels east of Monterey Street must accommodate drive access and on-site rear parking (refer to the Railroad Corridor section below Standards), although some of the required parking may be satisfied by paying in-lieu fees (refer to the In-Lieu Fees section below). These rear setbacks will help minimize visual and noise impact of commercial uses on adjacent residential properties and shall be measured from the rear property line.

## Corner Cutbacks

No building structure, fence, wall, landscape screening material, or other obstruction shall be higher than three feet above the adjacent street curb level within ten feet of an alley or driveway intersection; this is also called a “sight visibility triangle.” At the intersection of two streets, the sight visibility triangle is established by measuring 20 feet from the property line intersection at the corner and connecting the two points across the property. In the case of rounded corners, the sight visibility triangle is established by measuring the area circumscribed by the area of the curve and a chord to the curve; such chord being a line drawn between the point of tangency at the beginning of the curve and the point of tangency at the end of the curve. The foregoing provisions shall not apply to public utility poles, official warning signs or signals, or to places where the contour of the ground is such that there can be no cross visibility at the intersection. These requirements are set forth in Section 20.60 of the City of Gilroy Municipal Code.

## Building Height

To help strengthen the pedestrian environment and create a balanced street-to-building proportion, building requirements include both minimum and maximum heights. Building height is measured at the highest point on the primary street sidewalk, or front façade sidewalk, to the highest point of a building’s roof (parapet or ridgeline).

The Planning Division Manager may approve, through established processes, architectural features such as tower elements, elevator service shafts, and roof access stairwells which extend above the height limit.

Primary street sidewalk is defined in this District as sidewalks along Monterey Street. Front façade is defined by any façade that faces a street, sidewalk, or pedestrian paseo. This is intended to address the buildings that face Monterey Street on one side of the building and a paseo or sidewalk on the other side of the building.

### Parking

Off-street parking shall be located at the rear of the lot (with the exception of established public parking), with primary access from the side streets, alley, access easements, or via reciprocal access agreements. If there is no side or rear access possibility, then vehicle access to the rear may be taken from the street. New private parking facilities shall not be located adjacent to the Monterey Street sidewalk and shall not replace an existing or potential retail storefront.

### Spaces

Parking stall dimensions in this district may vary from City standard when approved by Planning Division Manager. The Planning Division Manager may consider and approve alternative parking solutions such as tandem and shared parking when appropriate.

### Access

Corner properties are encouraged to allow for reciprocal access to interior block properties to provide parking at the rear of the lot. Access easements across adjacent lots to the rear of a property are encouraged and shall be arranged between individual property owners.

### In-Lieu Fees

All uses may exercise the option to pay in-lieu parking fees, in an amount to be determined by the City, for any unbuilt required parking spaces. To accomplish this, the City must create a parking impact fund that enables the collection and expenditure of fees for the provision of parking in the Specific Plan area.

### Railroad Corridor

Properties between Lewis Street and Seventh Street on the west side of, and that abut the railroad corridor, must provide a 51-foot rear setback from the property line to accommodate on-site parking, an access drive, and a landscaped buffer. Additional articulation should be provided on building facades that face this corridor to promote an aesthetically pleasing view of the Downtown for rail patrons. A "standard" fencing design that will be commercial grade, six-foot tall, black powdercoated metal, with vertical slats and top and bottom rail as well as a five-foot minimum landscape planter area adjacent to the railroad corridor.

# DOWNTOWN EXPANSION DISTRICT



V LAND USE

# V

## Land Use

# DOWNTOWN EXPANSION DISTRICT CHARACTER



THE DISTRICT HAS OFFICE USES THAT SERVE LOCAL RESIDENTS



SIDEWALK CAFES AND RESTAURANTS ARE ENCOURAGED

### VISION

- Provides uses that focus more on serving the residents of Gilroy, primarily retail with some pedestrian-friendly service commercial
- Creates a pleasing “Welcome to Downtown Gilroy” image through beautification and building upkeep
- Monterey Street with street trees, improved sidewalks, identity signage, street furnishings and street crossings
- Buildings adorned with unique signage and colorful awnings line the sidewalk, stepping back for an occasional sidewalk cafe
- Parking lots are screened from street view, tucked behind or to the side of the buildings
- Architecture should reflect historic forms and materials which complement contemporary architecture design
- Paseos and sidewalks connect with the neighboring districts and rear parking lots

### DESIRED USES\*

- Retail
- Restaurants and cafes
- Offices above retail
- Some commercial services
- Visitor serving hotel, inn, B&B
- Residential above street frontage

### PROHIBITED USES\*

- Industrial/manufacturing
- Residential at street frontage

\* Refer to Permitted Uses Table for a complete list of uses

# DOWNTOWN EXPANSION DISTRICT STANDARDS

## INTENSITY

### Non Residential and/or Mixed-Use Projects

Max FAR: 2.5 FAR

The minimum density for the residential component of mixed use projects is twenty dwelling units per acre.

## SECTION VIEW

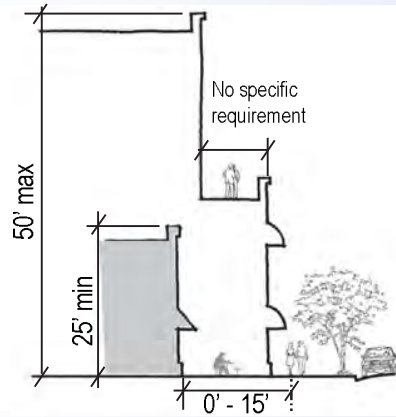

## PLAN VIEW

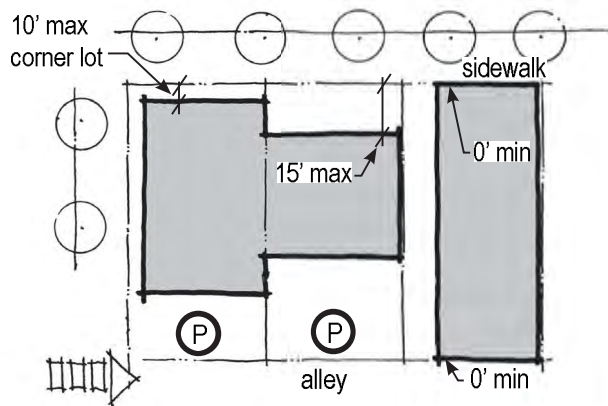

## PRIMARY USES (REFER TO PERMITTED USES TABLE FOR COMPLETE LIST)

### Non Residential

- Retail
- Lodging (B&B or inn)
- Entertainment Uses (cinema, playhouse)
- Service Commercial (video, dry cleaning, small appliance repair)
- Offices (all types, at ground floor)
- Restaurants

### Residential

- Residential (apartments above street level ground floor)

## URBAN FORM

### Setbacks:

- Front Min: 0' Front Max: 15'
- Side Min: 0' Rear Min: 0'
- Corner Lot Min<sup>2</sup>: 0' Corner Lot Max<sup>2</sup>: 10'
- <sup>1</sup>Parcels East of Monterey Street and North of Third Street 51'
- <sup>2</sup>Approval dependent on vehicle sight lines

### Building Height:

- Min: 25' at street front
- Max: 50' (3-4 stories)

### Building Form:

- Portions of the third and fourth stories shall be recessed from the front facade
- Buildings with > 40' of linear street frontage shall be designed to replicate traditional 20-40' facade (Refer to Design Guidelines)

### Railroad Corridor Standards Apply

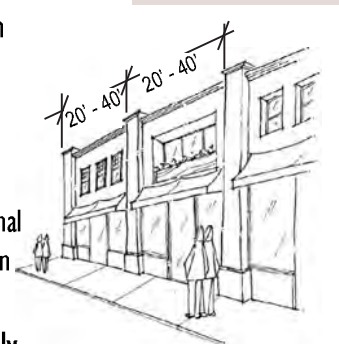

## OFF STREET PARKING

### Parking Location:

Permitted in rear or on the side of the building

### Parking Requirements:\*

- Retail/Entertainment: 1 space/500 sf
- Restaurants: 1 space/6 seats + 1 space/4 shift employees
- Offices: 1 space/400 sf
- Lodging: 1 space/room + 1 space/2 shift employees
- Service Commercial: 1 space/500 sf
- Residential units < 800 sf: 1 space/unit + 1 guest space/6 units
- Residential units > 800 sf: 1.5 spaces/unit + 1 guest space/4 units

\* All parking requirements may be satisfied by paying in-lieu fee



## Urban Form

The buildings in these districts will primarily face sidewalks and paseos. All parcels fronting Monterey Street must maintain a primary entrance and facade on that Street. A second entrance may be established for access to rear or sideyard parking. A business may operate with a primary entrance to the side or rear. As an extension of the Downtown Historic District, the Downtown Expansion District will continue the traditional urban form, retaining the same character and adhering to the same standards as the Downtown Historic District.

## Primary Uses

Allowable uses are outlined in the Specific Plan Permitted Uses Table. With the intent of encouraging pedestrian activity in the Downtown, residential is not allowed on the first floor at the street frontage of any building.

## Front Setbacks

As the Downtown's main thoroughfare, Monterey Street setbacks should aim to create a continuous built edge adjacent to the sidewalk, with slightly varying setbacks to allow for the creation of spaces for outdoor seating areas, outdoor dining, and shopping. These spaces will enrich the pedestrian experience and provide some visual variety within each block.

To help define the corners of street blocks and to create a framework in which the variable setbacks will have an impact on the streetscape, corner buildings shall be located closer to the street. However at no time will a building be allowed to intrude into the minimum corner cutback requirements (refer to the Corner Cutbacks section below).

## Allowable Front Setback Elements

To strengthen the pedestrian experience, allowable uses in the front setbacks include landscaping, retail display areas, and café or outdoor seating areas (so long as seating does not infringe on a seven-foot minimum clear zone of pedestrian passage in the public right of way or obstruct a four-foot minimum clear passage to building entrances).

Parking is not permitted within any front yard setback area or between the building and the street.

## Side Setbacks

To help create a continuous built edge along the streetscape edge and further define the front setback outdoor areas, side setbacks shall be used for pedestrian access on one side of the building only; adjacent properties should share pedestrian access points along common property lines.



## Rear Setbacks

Rear setbacks for parcels west of Monterey Street (along Gourmet Alley) should allow for a “shared space” between pedestrians and vehicles, acting as both a paseo system as well as retaining functionality for vehicle access, utility services, commercial loading, and spaces for employee parking.

Parcels east of Monterey Street must accommodate where possible drive access and on-site rear parking, although the required parking may be satisfied by paying in-lieu fees (refer to the In-Lieu Fee section below).

## Corner Cutbacks

No building structure, fence, wall, landscape screening material, or other obstruction shall be higher than three feet above the adjacent street curb level within ten feet of an alley or driveway intersection; this is also called a “sight visibility triangle.” At the intersection of two streets, the sight visibility triangle is established by measuring 20 feet from the property line intersection at the corner and connecting the two points across the property. In the case of rounded corners, the sight visibility triangle is established by measuring the area circumscribed by the area of the curve and a chord to the curve; such chord being a line drawn between the point of tangency at the beginning of the curve and the point of tangency at the end of the curve. The foregoing provisions shall not apply to public utility poles, official warning signs or signals, or to places where the contour of the ground is such that there can be no cross visibility at the intersection. These requirements are set forth in Section 20.60 of the City of Gilroy Municipal Code.

## Building Height

To help strengthen the pedestrian environment and create a balanced street-to-building proportion, building requirements include both minimum and maximum heights. Building height is measured at the highest point on the primary street sidewalk, or front façade sidewalk, to the highest point of a building’s roof (parapet or ridgeline).

The Planning Division Manager may approve through established processes, architectural features such as tower elements, elevator service shafts, and roof access stairwells which extend above the height limit.

Primary street sidewalk is defined in this District as sidewalks along Monterey Street. Front façade is defined by any façade that faces a street, sidewalk, or pedestrian paseo. This is intended to address the buildings that face Monterey Street on one side of the building and a paseo or sidewalk on the other side of the building.

### **Parking**

Off-street parking shall be located at the rear of the lot (with the exception of established public parking), with primary access from the side streets, alley, access easements, or via reciprocal access agreements. If there is no side or rear access possibility, then vehicle access to the rear may be taken from the street. New private parking facilities shall not be located adjacent to the Monterey Street sidewalk and shall not replace an existing or potential retail storefront.

### **Spaces**

Parking stall dimensions in this district may vary from city standard when approved by Planning Division Manager. The Planning Division Manager may consider alternative parking solutions such as tandem or shared parking when appropriate.

### **Access**

Corner properties are encouraged to allow for reciprocal access to interior block properties to provide parking at the rear of the lot. Access easements across adjacent lots to the rear of a property shall be arranged between individual property owners.

### **In-Lieu Fees**

All uses may exercise the option to pay in-lieu parking fees, in an amount to be determined by the City, for any unbuilt required parking spaces. To accomplish this, the City must create a parking impact fund that enables the collection and expenditure of fees for the provision of parking in the Specific Plan area.

### **Railroad Corridor**

Properties that abut the railroad corridor must provide “standard” fencing design that will be commercial grade, six-foot tall, black powdercoated metal, with vertical slats and top and bottom rail as well as a five-foot minimum landscape planter area adjacent to the railroad corridor. The intent of the City and Public Utilities Commission is to create a pedestrian pathway along the east side of the railroad corridor between Tenth Street and Leavesley Road. Additional articulation should be provided on building facades that face this corridor to promote an aesthetically pleasing view of the Downtown for rail patrons.

# CIVIC/CULTURAL ARTS DISTRICT

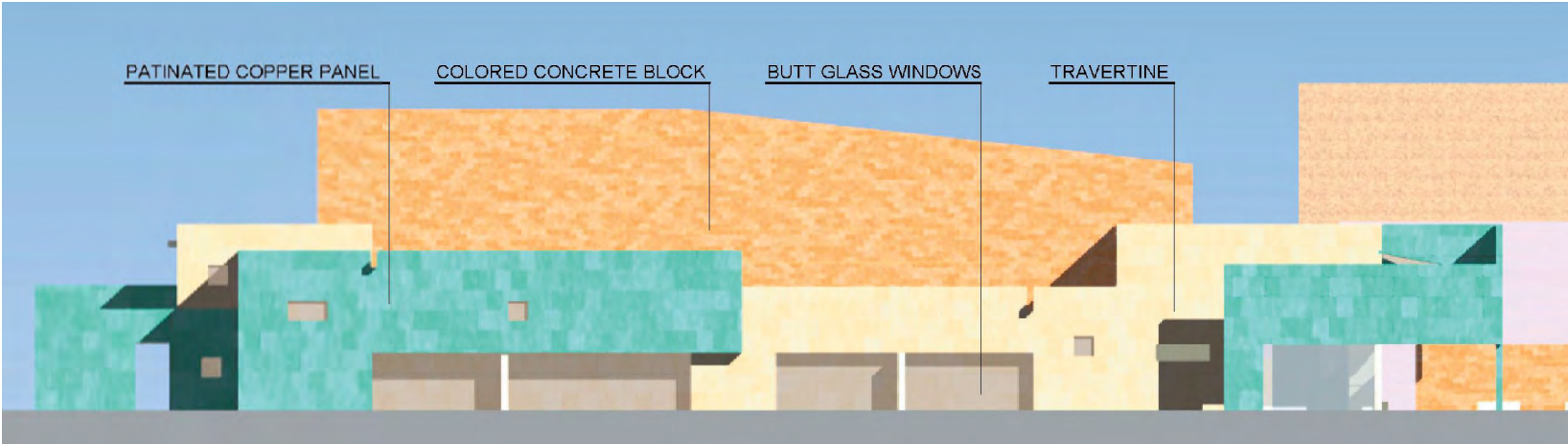

# V

## Land Use

# CIVIC/CULTURAL ARTS DISTRICT CHARACTER

## VISION

- Envisioned as the “heart” of civic and cultural activities
- Provides a regional destination for events, outdoor theatre, performances, and festivals on weekends and evenings with the “civic campus” activities feeding the surrounding uses during the week
- Provides community green space and culture/arts venues
- Creates a pedestrian-friendly district with wide sidewalks, street trees, benches and streetlights with banners and strong connections to the Downtown Historic District
- Allows for creative development opportunities in public/private mixed-use projects.
- Allows for more green space and public assembly space, which is a hallmark of this district, by encouraging large projects within the district to provide underground or under-building parking.



COMMUNITY GREEN SPACE IS PROVIDED



CULTURAL USES SUCH AS MUSEUMS ARE ENCOURAGED

## DESIRED USES\*

- Civic uses
- Residential
- Cultural uses, such as museums, theater, library, children’s museum, outdoor theater and events
- Retail uses serving civic center and arts center
- Passive recreational uses
- Office uses and office serving uses

## PROHIBITED USES\*

- Industrial/manufacturing
- Retail
- Service commercial

\* Refer to Permitted Uses Table for a complete list of uses

# CIVIC/CULTURAL ARTS DISTRICT STANDARDS

## INTENSITY

Monterey Street to Church Street

Non Residential and/or Mixed-Use Projects

Max FAR: 1.5 FAR

Church Street to Dowdy Street

Non Residential and/or Mixed-Use Projects

Max FAR: 1.0 FAR

## SECTION VIEW

Monterey Street to Church Street

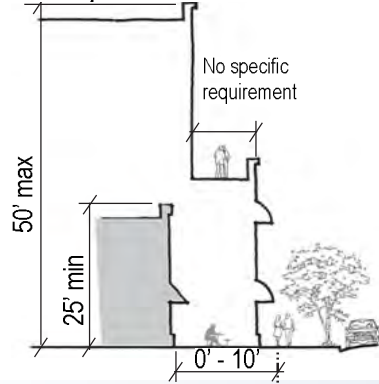

## PLAN VIEW

Monterey Street to Church Street

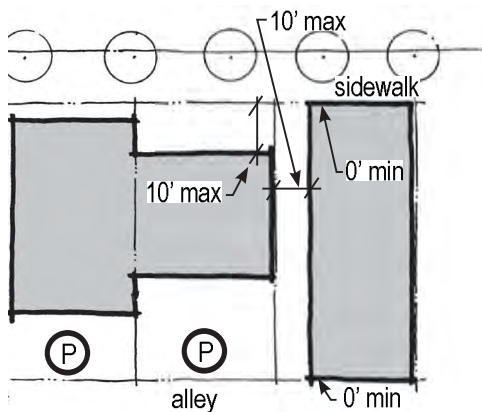

## PRIMARY USES (REFER TO PERMITTED USES TABLE FOR COMPLETE LIST)

### Non Residential

Civic (city hall, city offices)

Limited Retail (coffee, bakery, newsstand)

Cultural (library, museum, cultural arts center)

Professional Offices (legal, accounting, architecture)

### Residential

Residential (apartments, townhomes, live/work units above/behind ground floor)\*

\* Residential allowed only between Egleberry Street and Church Street

## URBAN FORM

### Setbacks:

Egleberry Street to Church Street

Front Min: 0' Front Max: 10'

Side Min: 0' Side Max: 10'

Rear Min: 10'

Corner Lots: 10'

Church Street to Dowdy Street

Front Min: 20'

Side Min: 10'

Rear Min: 10'

### Building Height:

Min: 25' at street front

Max: 50' (3-4 stories)

### Building Form:

Portions of the third and fourth stories shall be recessed from the front facade

## OFF STREET PARKING

### Parking Location:

Monterey Street to Church Street: Permitted in rear only

Church Street to Dowdy Street: Any location

### Parking Requirements:\*

Civic: 3 spaces/1000 sf

Cultural: 1 space/500 sf

Retail: 1 space/500 sf

Professional Office: 1 space/450 sf

Residential units < 800 sf: 1 space/unit + 1 guest space/6 units

Residential units > 800 sf: 1.5 spaces/unit + 1 guest space/4 units

\* All parking requirements may be satisfied by paying in-lieu fee



### Urban Form

Buildings in this district that are east of Egleberry Street shall either follow the Downtown Historic District Standards, as this area acts as the District's transition from a civic campus environment into an urbanizing downtown, or shall emulate the Art and Cultural Center's contemporary architectural style.

### Primary Uses

Allowable uses are outlined in the Specific Plan Permitted Uses Table. With the intent of encouraging pedestrian activity and events in the district, the uses focus on cultural uses, event uses, and commercial uses that will service the government offices and events. Residential uses are permitted only between Egleberry Street and Church Street.

### Front Setbacks

Variable setbacks along streets between Church Street and Dowdy Street within the Civic and Cultural District are intended to create a variety of spaces for outdoor seating areas and landscaping. These spaces will enrich the pedestrian experience and provide visual variety within these blocks.

Setbacks along Monterey Street, Egleberry Street, and Church Street are encouraged to reflect a downtown continuous built edge with less variety in setback. This arrangement is not intended to prohibit green space and public assembly space, which characterizes the district.

### Allowable Front Setback Uses

To strengthen the pedestrian experience, allowable uses in the front setbacks include landscaping, retail display areas, and café or outdoor seating areas.

Parking is permitted in any location for parcels within Church Street to Dowdy Street and is permitted in the rear only from Egleberry Street to Church Street.

### Side Setbacks

Side setbacks in the Civic/Cultural Arts District between Egleberry Street and Church Street shall help create a continuous built edge along the streetscape edge and further define the front setback outdoor areas. Parcels between Church Street and Dowdy Street will have larger side setbacks with wide sidewalks and pathways and community green space.



## Rear Setbacks

Rear setbacks create a transition between adjacent properties at the rear of the lot by allowing for open space and landscaping between buildings. Rear setbacks also create a place for vehicular access, utility services, and parking.

## Building Height

To help strengthen the pedestrian environment, along with providing a good environment for events, there is flexibility in maximum building height if the upper floors step back from the front façade. Building height is measured at the highest point on the primary street sidewalk to the highest point of a building's roof (parapet or ridgeline).

The Planning Division Manager may approve through established processes, architectural features such as tower elements, elevator service shafts, and roof access stairwells which extend above the height limit.

Primary street sidewalk is defined in this district as sidewalks along Monterey Street, Egleberry Street, Sixth Street and Seventh Street. Front façade is defined by any façade that faces a street sidewalk or pedestrian paseo.

## Parking

Off-street parking shall be located at the rear of the lot for all properties between Egleberry Street and Church Street, with primary access from the side streets, access easements, or via reciprocal access agreements. If there is no side or rear access possibility, then vehicular access to the rear may be taken from the street. Parking is not allowed in the front setback area. For properties between Church Street and Rosanna Street, parking is permitted in any location.

Parking stall dimensions in this district may vary from City standard when approved by the Planning Division Manager.

### Access

Corner properties are encouraged to allow for reciprocal access to interior block properties to provide parking at the rear of the lot. Access easements across adjacent lots to the rear of a property are encouraged and shall be required between individual property owners.

### In-Lieu Fees

All uses are required to provide on-site parking but shall have the option to pay in-lieu parking fees, in an amount to be determined by the City. To accomplish this, the City must create a parking impact fund that enables the collection and expenditure of fees for the provision of parking in the Specific Plan area.



**Land Use**

This page intentionally left blank.

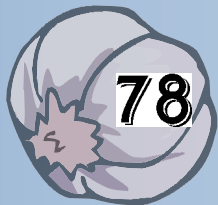

# TRANSITIONAL DISTRICT



V LAND USE

# V

## Land Use

# TRANSITIONAL DISTRICT CHARACTER

## VISION

- Gives “Small Town” feel
- Provides a wide mix of uses, such as lower density residential, service commercial, offices in residentially scaled buildings with traditional designs
- Wide streets may allow for some diagonal parking while the area also provides strategically located public parking
- Acts as a transition area buffering the Downtown Historic District from single family residential uses
- Provides strong pedestrian connections to the Downtown
- Maintains Historic Neighborhood District qualities in all new construction and renovations



PROVIDES PROFESSIONAL OFFICES IN FORMER RESIDENTIAL BUILDINGS



WIDE STREETS ALLOW FOR SOME DIAGONAL PARKING

## DESIRED USES\*

- A mix of residential densities, such as apartments, townhomes, and duplexes
- Residential and neighborhood serving uses, such as pharmacy, video rental, dry cleaner
- Professional and other offices and selected service uses, such as legal, financial, medical, dental, and appliance repair shops
- Small visitor serving uses such as B&Bs or small inn

## PROHIBITED USES\*

- Storage, industrial, manufacturing, distribution and storage yards and other similar uses
- Automobile services of all types
- Large commercial and retail chains and operations

\* Refer to Permitted Uses Table for a complete list of uses

# TRANSITIONAL DISTRICT STANDARDS

## INTENSITY

Non Residential and/or Mixed-Use Projects

Max FAR: 1.5 FAR

Stand Alone Residential

Max Density: 20 du/ac

## PRIMARY USES (REFER TO PERMITTED USES TABLE FOR COMPLETE LIST)

Non Residential

Professional Offices (legal, financial, medical, dental)

Lodging (B&B or small inn)

Service Commercial (pharmacy, video, dry cleaning)

Residential

Residential (stand alone, duplex, townhomes, condos and/or apartments above or behind ground floor uses)



## SECTION VIEW

West of Egleberry Street

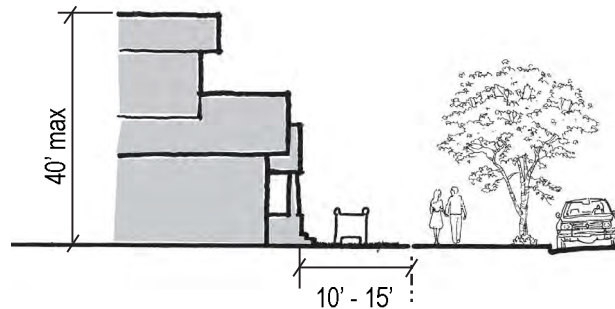

## URBAN FORM

West of Egleberry Street

Setbacks:

Front Min: 15' (10' with porch)

Side Min: 5'

Rear Min: 10'

Building Height:

Max: 40'

East of Egleberry Street

Setbacks:

Front Min: 0' Front Max: 15'

Side Min: 0'

Rear Min: 0' Rear Max: 5'

Corner Lots: 10'

Building Height:

Max: 40'

## PLAN VIEW

West of Egleberry Street

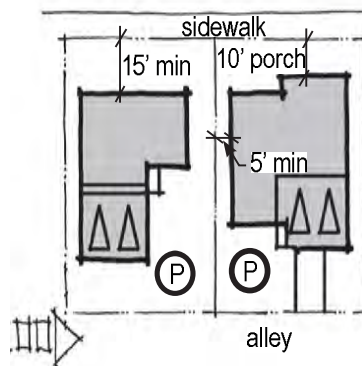

## OFF STREET PARKING

Parking Location:\*

Permitted at side or rear only

\* Where an alley occurs, access to residential parking and garages shall only be provided from the alley

Parking Requirements:\*

Professional Offices: 1 space/400 sf

Lodging: 1 space/room + 1 space/2 shift employees

Service Commercial: 1 space/500 sf

Residential units < 800 sf: 1 space/unit + 1 guest space/6 units

Residential units > 800 sf: 1.5 spaces/unit + 1 guest space/4 units

\* 50% of parking requirements (except lodging and residential) may be satisfied by paying in-lieu fee

### Primary Uses

Allowable uses are outlined in the Specific Plan Permitted Uses Table. This District accommodates a range of uses and building types, including single family residential houses converted into offices, multi-family buildings, and mixed-use buildings. The following regulations help create a cohesive and compatible District that serves to buffer the adjacent neighborhoods from the Downtown.

### Front Setbacks

Variable setbacks along streets within this District will create a variety of spaces for outdoor seating areas and landscaping. These spaces will enrich the pedestrian experience and provide visual variety within each block.

To encourage front porches on buildings and minimize garage door impacts, there is flexibility allowed in setbacks measured from the front property line.

### Allowable Front Setback Uses

To strengthen the pedestrian experience, allowable uses in the front setbacks include landscaping, retail display areas, and café or outdoor seating areas.

Parking is not permitted in the front yard setbacks.

### Rear Setbacks

Rear setbacks create a transition between adjacent properties at the rear of the lot by allowing some open space and landscaping between buildings. Rear setbacks also create a place for vehicular access, utility services, and parking.

### Building Height

Building height is measured at the highest point on the primary street sidewalk to the highest point of a building's roof (parapet or ridgeline). The Planning Division Manager may approve architectural features such as tower elements, elevator service shafts, and roof access stairwells which extend above the height limit.

Primary street sidewalk is defined in this district as sidewalks along Egleberry Street. Front façade is defined by any façade that faces a street or sidewalk.



## Parking

Off-street parking shall be located at the rear or side of the lot, with primary access from the side streets, access easements, or via reciprocal access agreements when feasible. If there is no side or rear access possibility, then vehicle access to the rear may be taken from the front of the lot. Parking is not permitted within any front yard setback area or between the building and the street.

Parking stall dimensions in this district may vary from City standard when approved by Planning Division Manager.

### Access

Corner properties are encouraged to allow for reciprocal access to interior block properties to provide parking at the rear of the lot. Access easements across adjacent lots to the rear of a property are encouraged and shall be required between individual property owners.

### In-Lieu Fees

Uses other than residential or lodging have the option to pay in-lieu parking fees, in an amount to be determined by the City, for up to 50% of any unbuilt required parking spaces. To accomplish this, the City must create a parking impact fund that enables the collection and expenditure of fees for the provision of parking in the Specific Plan area.

# V

## Land Use



DETACHED GARAGES SHOULD BE ARCHITECTURALLY INTEGRATED INTO THE OVERALL BUILDING DESIGN



FRONT SETBACKS SIMILAR TO A RESIDENTIAL DISTRICT ARE PERMITTED

## TRANSITIONAL DISTRICT DESIGN GUIDELINES

### Architectural Character

The intent of the guidelines is to build and maintain a neighborhood with diversity in the architectural styles, building type, materials and details, building square footage, setbacks, lot widths, and landscaping. No one particular architectural theme is being promoted, but rather the emphasis is to promote variety within a traditional neighborhood design framework. In the Transitional District, there should be a soft, attractive, and smooth transition between the commercial core and the surrounding residential neighborhoods.

### Site Planning

- Alternatives to solid paved driveways such as brick, cobblestone, or interlocking pavers are encouraged. However, such enhanced surfaces may not encroach into the sidewalk.
- Carports, detached garages and accessory structures should be architecturally integrated into the overall design of the project with similar materials and details as the residences.
- Fencing and wall materials should be compatible with the building and should be used to reinforce the architectural theme of the building. Stacked rock or battered base walls are appropriate, as is decorative wood fencing.

### Building Additions and Conversions

- Additions to existing structures are encouraged only on the sides and rear of the existing building.
- Materials, window shapes, architectural trim, roof form and other architectural elements of additions should match those of the existing building.
- Conversions of residential structures to commercial use shall retain the residential character of the existing building.



- Existing architectural moldings, ornamentation and other interesting detailing should be retained and repaired or replaced to match the original detail.
- New development should provide similar ornamentation as existing historic structures in the area to enhance the character of the area.
- Siding should wrap around the outside corners of the building to the fence line at a minimum. The use of siding on entire building is recommended.

### Porches, Stoops, Balconies, Courtyards & Patios

- Porches, stoops, and balconies are encouraged to complement and enhance overall building design and function and to vary building planes.
- Covered porches or patios at the first floor level oriented toward the front and/or side yard should be a minimum of six feet in depth, and shapes, sizes, and setbacks should vary from house to house.
- Victorian and bungalow style porches should include overhangs, heavy wood trellis structures or traditional lattice or picket surround courtyards whenever possible.

### Building Articulation

- Built-up sills and trim should be used to create surface relief and texture.
- Black, bronze, silver, gold, or natural anodized aluminum and dark tinted or reflective windows are strongly discouraged.
- True divided light glazing and external mullions are preferred over internal mullions. If true divided lights are not feasible due to cost, consider the following alternatives:
  - Plant-on external mullions may have the same visual effect at a lower cost. However, these have a tendency to break off over time. Periodic repairs may be required.
  - Windows with internal mullions (grids) vary in terms of appearance. Select windows that utilize thick, dimensional grids rather than thin strips.



NEW DEVELOPMENTS SHOULD PROVIDE SIMILAR ORNAMENTATION TO EXISTING BUILDINGS (REFLECTIVE OF DEVELOPMENT ON THE NORTHEAST PORTION OF EGLEBERRY STREET)



THERE SHOULD BE A SMOOTH TRANSITION BETWEEN COMMERCIAL AND RESIDENTIAL USES (REFLECTIVE OF DEVELOPMENT ON THE WEST AND SOUTHEAST PORTION OF EGLEBERRY STREET)

# V

## Land Use



WINDOWS WITH FUNCTIONAL SHUTTERS ARE ENCOURAGED

- Use of functional or decorative shutters is encouraged when appropriate to the architectural style. The shutters should be sized proportionate to the adjacent window.
- Roof forms should be consistent with the neighborhood character. Dormers, eaves, exposed rafter tails, exposed roof beams, detailed corbels, turrets, eyebrows and triangular knee braces are common elements of the existing neighborhood that are encouraged in new designs.
- Articulated chimneys can add to the architectural character and are encouraged.



EXPOSED RAFTER TAILS AND TRIANGULAR KNEE BRACES ARE COMMON ELEMENTS OF THE EXISTING NEIGHBORHOOD

# CANNERY DISTRICT



# V

## Land Use

# CANNERY DISTRICT CHARACTER



RESIDENTIAL LOFTS ARE A PRIMARY USE



ACTS AS A NON-TRADITIONAL, MORE URBANE PLACE FOR ECLECTIC ARCHITECTURE

## VISION

- Provides ample live/work opportunities, artist lofts, home office uses and residential development that serves young professionals, small families and artisans
- Acts as a non-traditional, more urbane place for eclectic architecture
- Transforms this light industrial area into a contemporary, higher density housing district/arts district

## DESIRED USES\*

- Residential (lofts, apartments, flats, live/work spaces)
- Offices, high-tech incubator businesses
- Selected commercial services and restaurants
- Light assembly and artist work spaces and yards, cottage industries
- Art, dance, gymnastic and music studios or galleries
- Theater

## PROHIBITED USES\*

- Heavy industrial/manufacturing
- Storage
- Repair facilities
- Outdoor storage
- Larger retail not suitable to the character of the District

\* Refer to Permitted Uses Table for a complete list of uses

# CANNERY DISTRICT STANDARDS

## INTENSITY

### Non Residential and/or Mixed-Use Projects

Max FAR: 2.5 FAR

The minimum density for the residential component of mixed use projects is twenty units per acre.

### Stand Alone Residential

Density: 20 to 40 du/ac

## SECTION VIEW

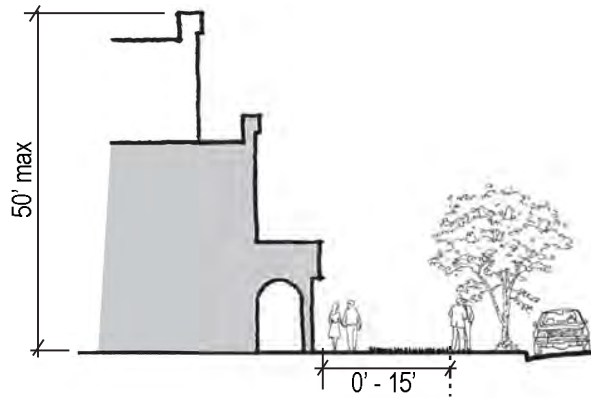

## PLAN VIEW

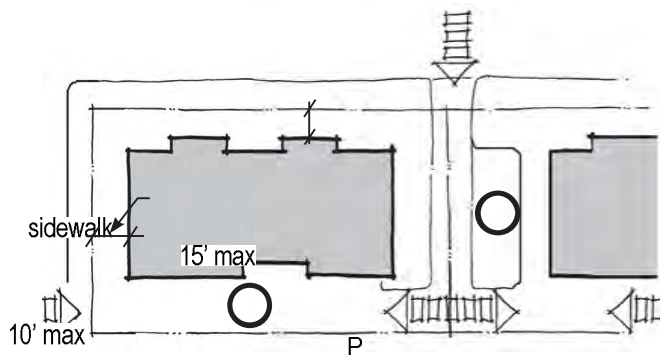

## PRIMARY USES (REFER TO PERMITTED USES TABLE FOR COMPLETE LIST)

### Non Residential

- Offices (all types)
- Service Commercial (video, dry cleaning)
- Research & Development (small incubator businesses)
- Light Assembly/Artisan

### Residential

- Residential (stand alone, duplexes, townhomes, condos, lofts, live/work space, and/or apartments above/behind ground floor use)

## URBAN FORM

### Setbacks:

- Front Min: 0' Front Max: 15'
- Side Min: 0' Side Max: 10'
- Rear Min: 0'

### Building Height:

- Min: 25' at street front (excluding porch or entry element)
- Max: 50' (3-4 stories)

## PARKING

### Parking Location:

Permitted at side or rear

### Parking Requirements:\*

- Offices: 1 space/400 sf
- Service Commercial: 1 space/500 sf
- Light Assembly: 1 space/1,000 sf
- Research & Development: 1 space/1,000 sf
- Residential units < 800 sf: 1 space/unit + 1 guest space/6 units
- Residential units > 800 sf: 1.5 spaces/unit + 1 guest space/4 units

\* 50% of parking requirements may be satisfied by paying in-lieu fee



### Primary Uses

Allowable uses are outlined in the Specific Plan Permitted Uses Table. The Cannery District focuses on providing live/work and higher density residential opportunities in an industrial setting, making development and therefore cost of living more affordable. This land use will provide housing stock for the urban core in a way that blends with other light industrial uses along the railroad corridor, meanwhile respecting the adjacent commercial/retail downtown.

### Front Setbacks

Setbacks along streets surrounding this district allow for a variety of spaces for outdoor seating areas and landscaping. These spaces will enrich the pedestrian experience and provide visual variety within each block.

### Allowable Front Setback Elements

To strengthen the pedestrian experience, allowable elements in the front setbacks include landscaping, commercial artisan display, or outdoor seating areas.

Parking is not permitted in front of buildings.

### Side Setbacks

To create a more urban dense setting, the minimum side setback in this district shall be five feet.

### Rear Setbacks

Rear setbacks create a transition between adjacent properties at the rear of the lot by allowing some open space and landscaping between buildings and in this district in particular, a buffer from the adjacent railway. Rear setbacks also create a place for service and parking.

### Building Height

To help create a stronger pedestrian environment and the desired character of the Cannery District, buildings have both a required minimum height as well as a maximum allowable height. Building height is measured at the highest point on the primary street sidewalk to the highest point of a building's roof (parapet or ridgeline). The Planning Division Manager may approve architectural features such as tower elements, elevator service shafts, and roof access stairwells which extend above the height limit.

Primary streets are defined in this district as Railroad Street and Old Gilroy Street; at the corner of these two streets, Old Gilroy Street is the primary street.



## Parking

Off-street parking shall be located at the rear or side of the lot, with primary access from the side streets, access easements, or reciprocal access agreements when feasible. If there is no side or rear access possibility, then vehicular access to the rear may be taken from the street. Parking is not permitted within any front yard setback area or between the building and the street.

### Spaces

Parking stall dimensions in this district may vary from City standard when approved by the Planning Division Manager.

### Access

Corner properties are encouraged to allow for reciprocal access to interior block properties to provide parking at the rear of the lot. Access easements across adjacent lots to the rear of a property are encouraged and shall be required between individual property owners.

### In-Lieu Fees

Uses other than residential or lodging are not required to provide on-site parking but shall have the option to pay in-lieu parking fees, in an amount to be determined by the City, for up to 50% of any unbuilt required parking spaces. To accomplish this, the City must create a parking impact fund that enables the collection and expenditure of fees for the provision of parking in the Specific Plan area.

## Railroad Corridor

Properties that abut the railroad corridor must provide a landscaped buffer at the property line. A “standard” fencing design that will be commercial grade, six-foot tall, black powdercoated metal, with vertical slats and top and bottom rail as well as a five-foot minimum landscape planter area shall be provided adjacent to railroad corridor. The intent of the City and Public Utilities Commission is to create a pedestrian pathway along the east side of the railroad corridor between Tenth Street and Leavesley Road. Additional articulation should be provided on building facades that face this corridor to promote an aesthetically pleasing view of the Downtown for rail patrons.

# V

## Land Use



THE ARCHITECTURE IN THE CANNERY DISTRICT SHOULD BE INNOVATIVE AND EXCITING



A CONTEMPORARY INDUSTRIAL CHARACTER IS ENCOURAGED

## CANNERY DISTRICT DESIGN GUIDELINES (LIVE/WORK, HIGH DENSITY/HOUSING)

### Architectural Character

The intent in the Cannery District is to reuse existing structures when feasible and infill with new structures that have a more contemporary industrial character. The architecture in the area should be innovative and exciting and should combine an interesting mix of rustic and modern materials, such as board and batten buildings with steel and metal roof structures. The architecture should be imaginative yet functional and should present a surprising use of forms and protrusions that tilt or angle in unusual directions. The following guidelines apply to both building reuse and infill projects.

### Site Planning and Design

- A variety of building heights and setbacks shall be incorporated into the design of sites to create diversity and avoid long, monotonous building facades.
- The incorporation of porches into the building's design will denote entries and break-up building mass.
- Building entrances shall be clearly defined and easily accessible from public transit stops.
- Whenever possible and appropriate, pedestrian linkages shall be provided to nearby neighborhoods.
- Garage doors shall not face the street.

### Parking Lot Design and Screening

- Parking shall be located under or behind structures when feasible.

### Building Design and Architectural Character

- Contemporary industrial architecture is encouraged.
- Materials that are reflective of live/work lofts, industrial uses and the railroad uses, such as metal, glass, wood, and corrugated aluminum, are encouraged.

# GATEWAY DISTRICT



**V LAND USE**

# V

## Land Use

# GATEWAY DISTRICT CHARACTER



AN ENHANCED STREET ENVIRONMENT IS PROVIDED

### VISION

- As the primary entryway to Downtown, street beautification and architectural enhancement are primary goals
- Provides a mix of uses that focus more on commercial services
- Provides an enhanced street environment with street trees, landscaped medians and curbs, gutters and sidewalks
- Parking areas are screened and beautified
- A mix of contemporary architectural styles will reflect the City's variety



A MIX OF USES THAT FOCUS ON COMMERCIAL SERVICES IS SUGGESTED

### DESIRED USES\*

- Offices
- Service commercial
- Residential in medium to high densities (primarily on the southwest part of Monterey Street)
- Visitor serving uses, such as hotel, inn and B&B

### PROHIBITED USES\*

- Heavy industrial/manufacturing
- Storage facilities
- Pedestrian-oriented retail

\* Refer to Permitted Uses Table for a complete list of uses

# GATEWAY DISTRICT STANDARDS

## INTENSITY

Non Residential and/or Mixed-Use Projects

Max FAR: 0.75 FAR

Stand Alone Residential

Max Density: 30 du/ac

## SECTION VIEW

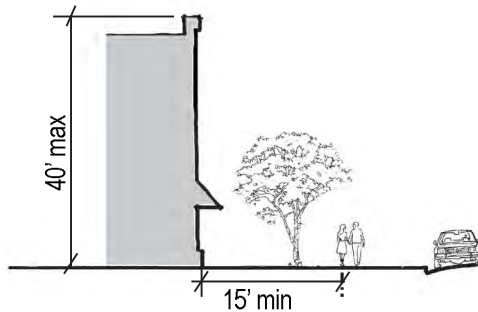

## PLAN VIEW

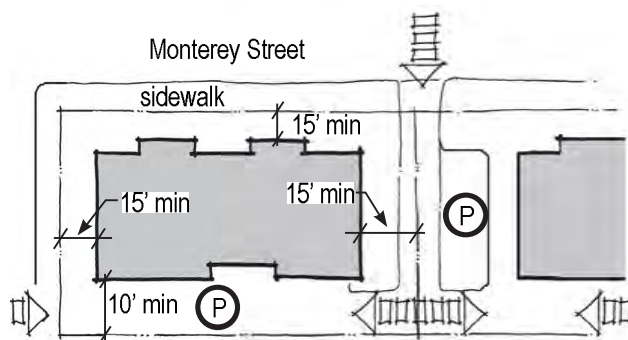

## PRIMARY USES (REFER TO PERMITTED USES TABLE FOR COMPLETE LIST)

### Non Residential

Offices (all types)

Lodging (hotel or inn)

Service Commercial (auto related, service and repair, home improvements)

### Residential

Residential (stand alone, duplexes, townhomes, condos, lofts, live/work space, and/or apartments above/behind ground floor use)

## URBAN FORM

### Setbacks:

Front Min: 15'

Side Min: 15'

Rear Min: 10'

Corner Min: 15'

### Building Height:

Max: 40' (2-3 stories)

Railroad Corridor Standards Apply

## OFF STREET PARKING

### Parking Location:

Any location - Maximum of 25% of required parking may be located between the building and street with berming and planting between the street and parking

### Parking Requirements:\*

Offices: 1 space/350 sf

Lodging: 1 space/room + 1 space/2 shift employees

Service Commercial: 1 space/400 sf

Residential units < 800 sf: 1 space/unit + 1 guest space/6 units

Residential units > 800 sf: 1.5 spaces/unit + 1 guest space/4 units

\* All parking requirements must be met on-site; Shared parking reduction of 25% for vertically mixed-use projects

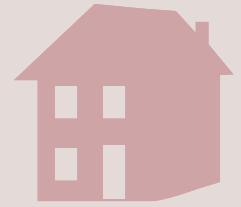

## Urban Form

The buildings in this District will primarily face onto Gilroy's main downtown thoroughfare. Whereas this District is on the fringe of the downtown urban core, it acts as a "gateway" into the Downtown leaving a first and last impression. Buildings along Monterey Street must treat their Monterey Street frontage as their primary entrance and front façade. Since this District has unique lot configuration and building placement, setbacks are more flexible in this District than in other Districts. The intent of this District is to provide a nice publicly and privately landscaped area as a gateway into Downtown Gilroy.

## Primary Uses

Allowable uses are outlined in the Specific Plan Permitted Uses Table. Residential is not allowed on the first floor at the street frontage of any building. Stand alone multi-family residential may exist off of Monterey Street.

## Front Setbacks

As the entrance to Downtown Gilroy, the Gateway District should create a transition into Downtown to announce arrival. This transition can be accomplished through street beautification and greenways along Monterey Street.

Varied front setbacks will provide opportunity for this beautification.

## Allowable Front Setback Uses

Parking is permitted within the front yard setback area but must be screened from street view.

## Side Setbacks

To create an efficient circulation network, adjacent properties should share vehicular and pedestrian access points along common property lines wherever possible to minimize curb cuts along Monterey Street.

## Rear Setbacks

Rear setbacks create a transition between adjacent properties at the rear of the lot by allowing for open space and landscaping between buildings. Rear setbacks in this District should allow for vehicular access, utility services, and parking.

Parking in the rear is encouraged where possible. Where opportunities for storage or functional service areas exist in the rear, these areas should be screened from adjoining properties (i.e. auto repair storage or service areas).



## Building Height

To help strengthen the pedestrian environment and create a balanced street-to-building proportion, building requirements include both minimum and maximum heights. This District should allow for two to three story structures to form a pleasant looking arrival to Downtown.

## Parking

Parking, although preferred in the rear or on the side, is allowed in any location so long as it is well screened from Monterey Street, bermed and adequately landscaped with shade trees to minimize the impact of large paved asphalt areas.

### Access

Corner properties are encouraged to allow for reciprocal access to interior block properties to provide parking at the rear of the lot. Access easements across adjacent lots to the rear of a property are encouraged and shall be required between individual property owners.

### Shared Parking

When two or more land uses within a building have distinctly different hours of operation, such uses may develop shared parking agreements to satisfy the standards. The amount of cumulative parking required may be reduced up to 25% with a shared parking agreement.

## Railroad Corridor

Additional articulation should be provided on building facades that face this corridor to promote an aesthetically pleasing view of the Downtown for rail patrons. A “standard” fencing design that will be commercial grade, six-foot tall, black powdercoated metal, with vertical slats and top and bottom rail as well as a five-foot minimum landscape planter area shall be provided adjacent to the railroad corridor. The intent of the City and Public Utilities Commission is to create a pedestrian pathway along the east side of the railroad corridor between Tenth Street and Leavesley Road.

# V

## Land Use



PARKING LOTS SHOULD BE SCREENED BY LANDSCAPING



PARKING LOTS CAN ALSO BE SCREENED BY ROLLING EARTH BERMS AND CHANGES IN ELEVATION

## GATEWAY DISTRICT DESIGN GUIDELINES

### Parking Lot Design and Screening

- Parking should be located behind buildings whenever possible. If this location is not possible, parking shall be well screened from view.
- Parking lots adjacent to and visible from public streets shall be adequately screened from vehicle view through one or more of the following:
  - rolling earth berms (2:1 slope)
  - low screen walls
  - landscaping, or
  - changes in elevation.
- Screening shall be a minimum of three feet in height at the time of installation, measured from the interior of the parking lot.
- Parking areas and cars should not be the dominant visual element of the site or streetscape.