



# LA JOLLA COVE RESEARCH CENTER

505 COAST BOULEVARD, LA JOLLA, CALIFORNIA 92037

## CHRIS DURBIN

Associate | Lic.# 02227661  
858.458.3339 | [cdurbin@voitco.com](mailto:cdurbin@voitco.com)

## MILES ARNOLD

Senior Associate | Lic.#02094013  
858.458.3324 | [marnold@voitco.com](mailto:marnold@voitco.com)

# ***Voit***

REAL ESTATE SERVICES

Rooftop Terrace with Ocean Views



Common Area Conference Center and Amphitheatre



Executive Office Wing with Private Balconies



Office Views



Lab Area





81,892 SF



1.95/1,000 SF (Free Covered)  
Additional parking available



On-Site Management & Maintenance



Zoning: LJ PD-5  
(Office, Medical and Lab)



Back-Up Generator



Five (5) Stories; Elevator Served



Walkable Amenities in Village of La Jolla



Autoclave / Glass Wash



Shared Conference Center (8-10 people)  
Indoor Amphitheater (110 person)



Vivarium Spaces

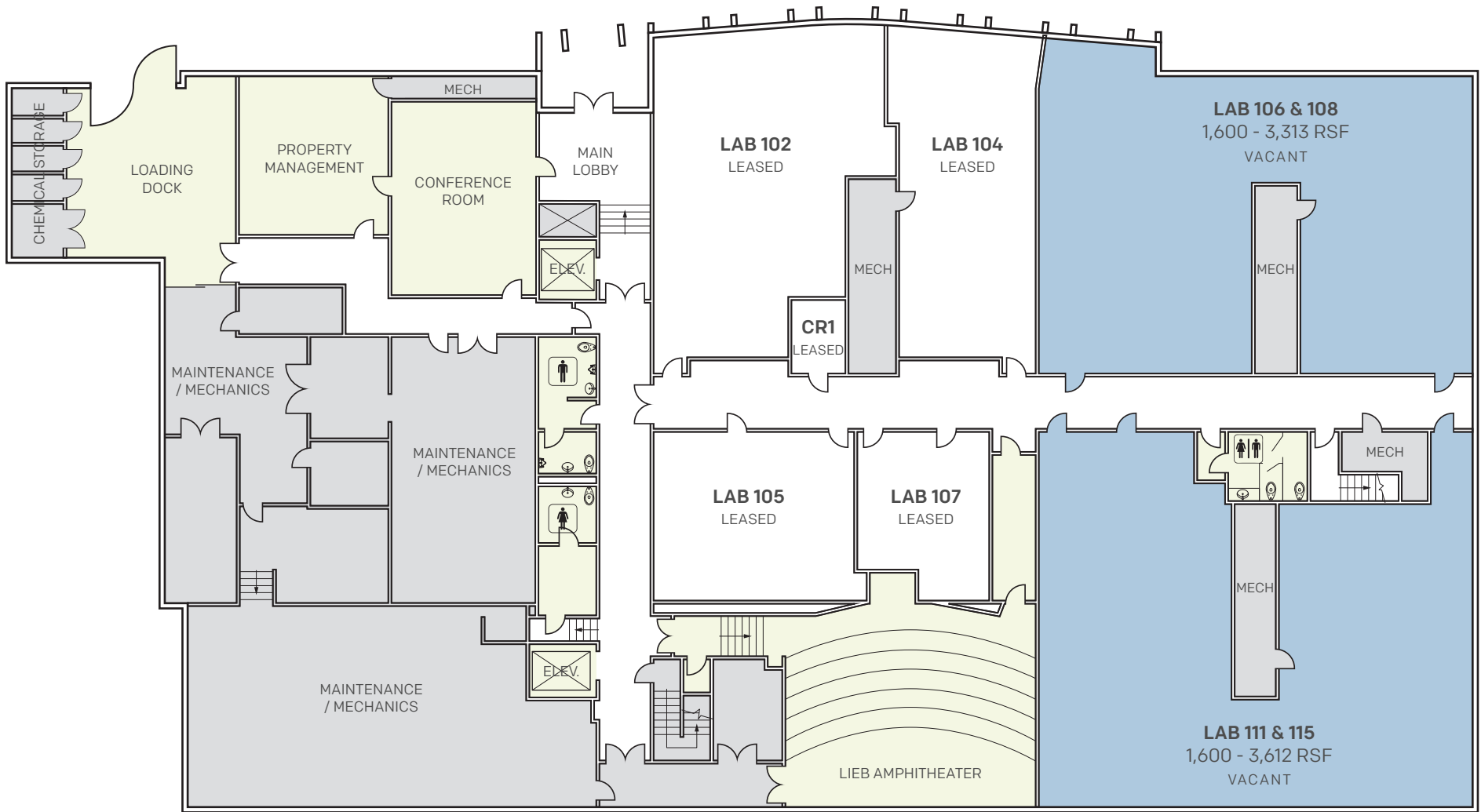

## FLOOR PLANS

### FIRST FLOOR

VACANT SPACE

BUILDING SERVICES

BUILDING AMENITIES

## CURRENT AVAILABILITIES

SUITE	RSF	MO. RATE PSF	AVAILABLE
<b>Lab 106/108</b>	3,313 SF*	\$3.50/SF NNN	Now

SUITE	RSF	MO. RATE PSF	AVAILABLE
<b>Lab 111/115</b>	3,612 SF*	\$3.25/SF NNN	Now

\* = OPTION TO DEMISE  
NNN = \$1.05/SF

# FLOOR PLANS

## FIRST FLOOR

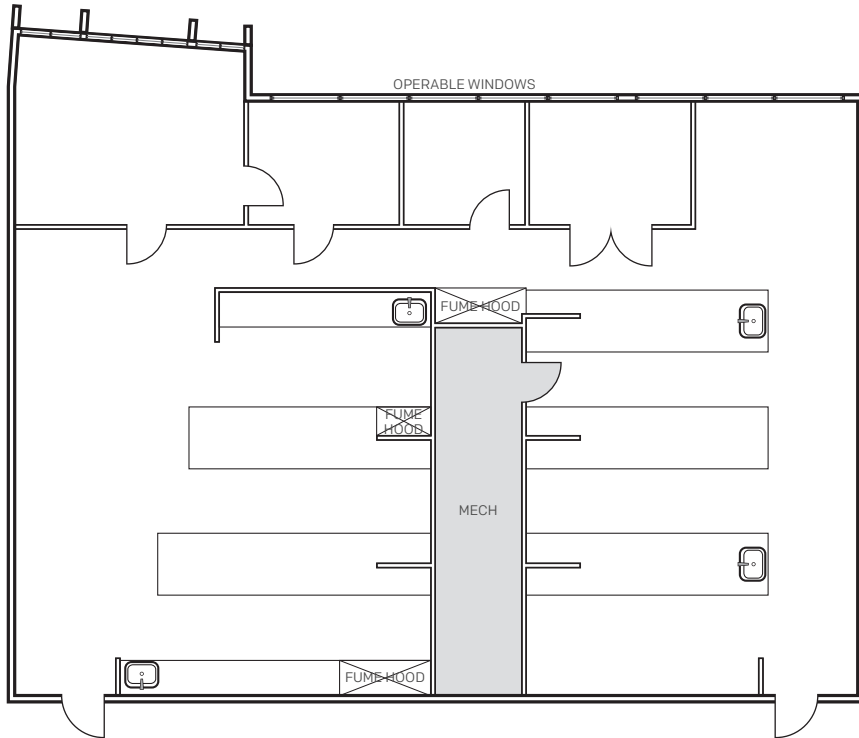

### SUITE 106/108

RSF	MO. RATE PSF	AVAILABLE
3,313 SF	\$3.50/SF NNN	Now

- Operable Windows
- (1) Conference Room
- (3) Offices
- (3) Fume Hoods
- (4) Sinks

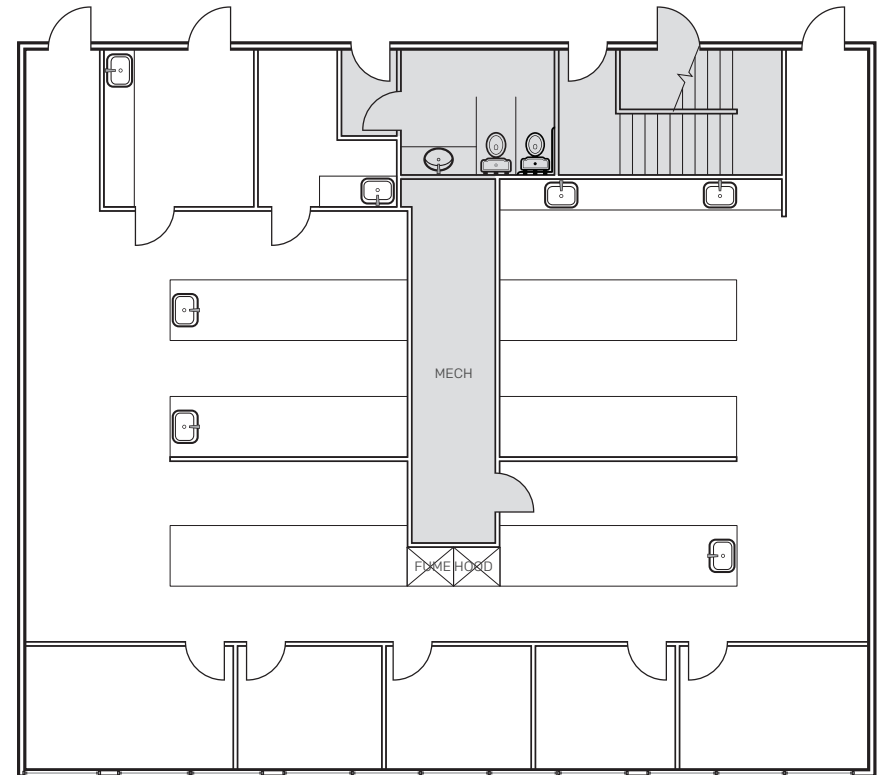

### SUITE 111/115

RSF	MO. RATE PSF	AVAILABLE
3,612 SF	\$3.25/SF NNN	Now

- Operable Windows
- Break Area
- (5) Offices
- (2) Fume Hoods
- (7) Sinks

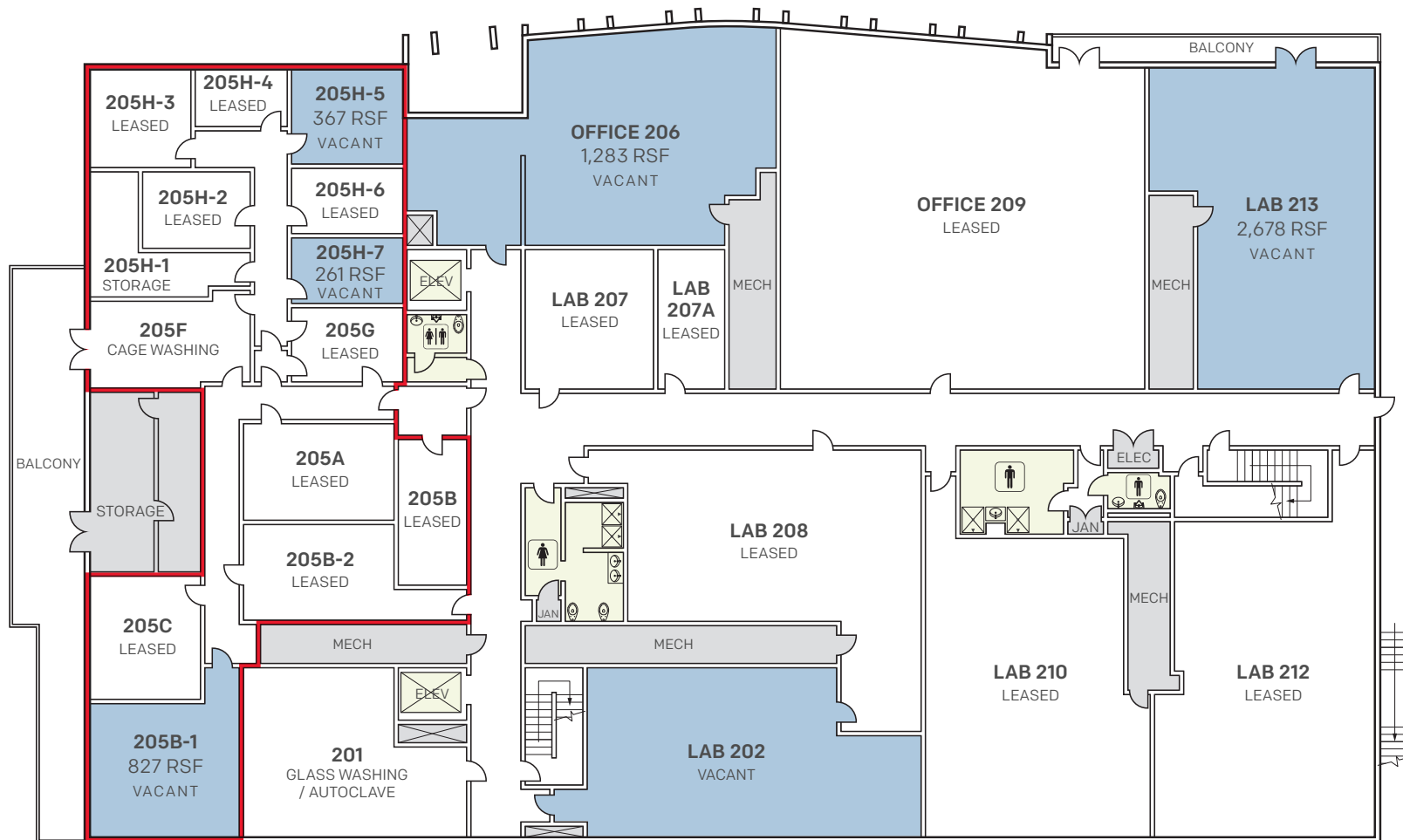

## FLOOR PLANS

### SECOND FLOOR

VACANT SPACE

BUILDING SERVICES

BUILDING AMENITIES

VIVARIUM SPACE

## CURRENT AVAILABILITIES

SUITE	RSF	MO. RATE PSF	AVAILABLE
Lab 205 B-1	827 SF	\$3.50/SF NNN	Now
Lab 205 H-5	367 SF	\$3.15/SF NNN	30-Days
Lab 205 H-7	261 SF	\$3.15/SF NNN	Now
Lab 202	1,652 SF	\$3.25/SF NNN	Now

SUITE	RSF	MO. RATE PSF	AVAILABLE
Office 206	1,283 SF	\$5.00/SF FSG	Now
Lab 213	2,678 SF	\$3.75/SF NNN	Now

NNN = \$1.05/SF

# FLOOR PLANS

## SECOND FLOOR

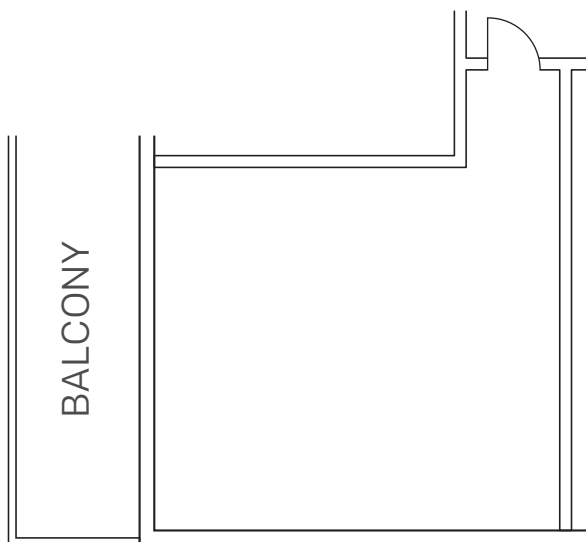

### SUITE 205/B-1

RSF	MO. RATE PSF	AVAILABLE
827 SF	\$3.50/SF NNN	Now
<ul style="list-style-type: none"> <li>• Open Area</li> <li>• Vivarium Space</li> </ul>		

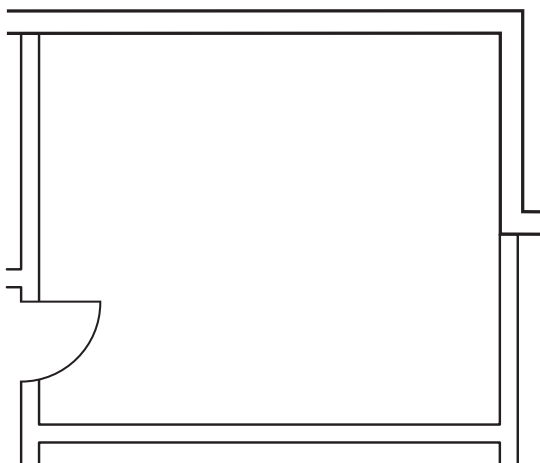

### SUITE 205/H-5

RSF	MO. RATE PSF	AVAILABLE
367 SF	\$3.15/SF NNN	30-Days
<ul style="list-style-type: none"> <li>• Open Area</li> <li>• Vivarium Space</li> </ul>		

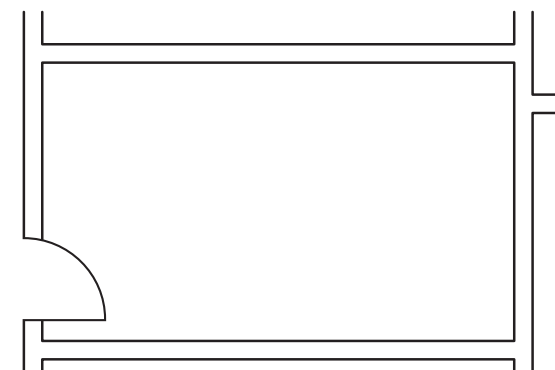

### SUITE 205/H-5

RSF	MO. RATE PSF	AVAILABLE
261 SF	\$3.15/SF NNN	Now
<ul style="list-style-type: none"> <li>• Open Area</li> <li>• Vivarium Space</li> </ul>		

# FLOOR PLANS

## SECOND FLOOR

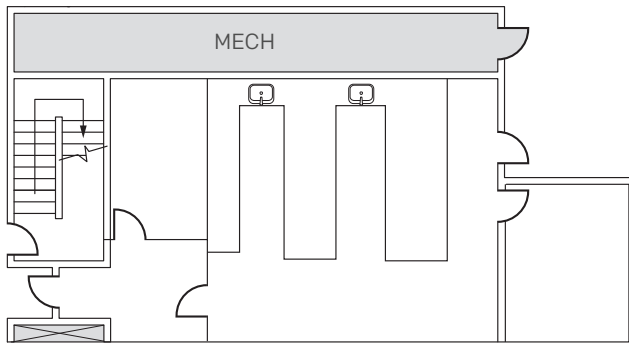

### SUITE 202

RSF	MO. RATE PSF	AVAILABLE
1,652 SF	\$3.25 NNN	Now
<ul style="list-style-type: none"> <li>• (2) Offices</li> <li>• (2) Sinks</li> </ul>		<ul style="list-style-type: none"> <li>• (1) Lab Support Room</li> </ul>

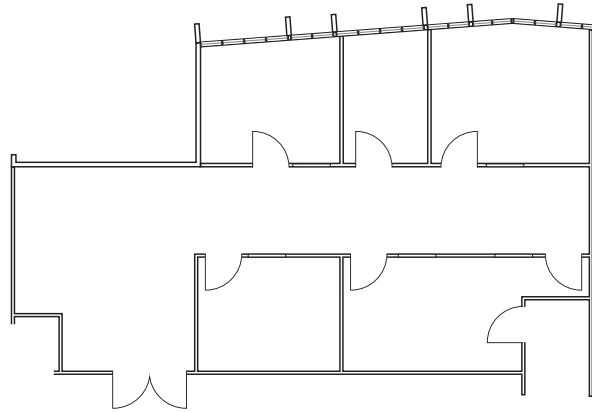

### SUITE 206

RSF	MO. RATE PSF	AVAILABLE
1,283 SF	\$5.00/SF FSG	Now
<ul style="list-style-type: none"> <li>• Open Area</li> <li>• (1) Conference Room</li> </ul>		<ul style="list-style-type: none"> <li>• Reception</li> <li>• (4) Offices</li> </ul>

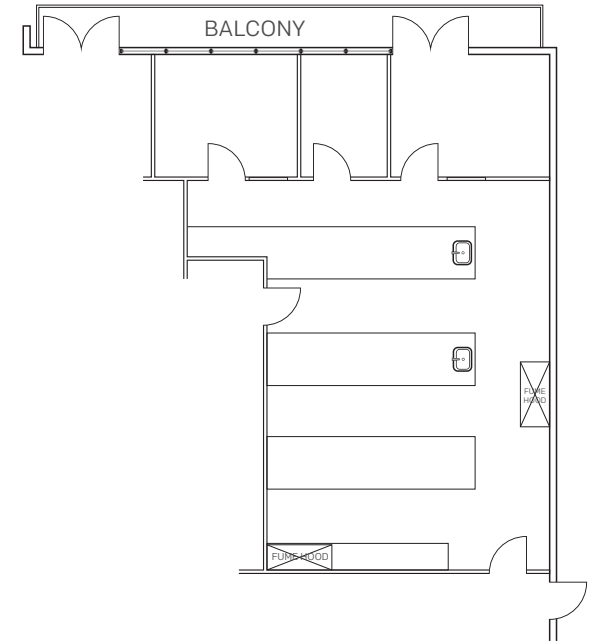

### SUITE 213

RSF	MO. RATE PSF	AVAILABLE
2,678 SF	\$3.75/SF NNN	Now
<ul style="list-style-type: none"> <li>• Open Lab Space</li> <li>• (3) Offices</li> <li>• Balcony Access</li> </ul>		<ul style="list-style-type: none"> <li>• (2) Fume Hoods</li> <li>• (2) Sinks</li> </ul>

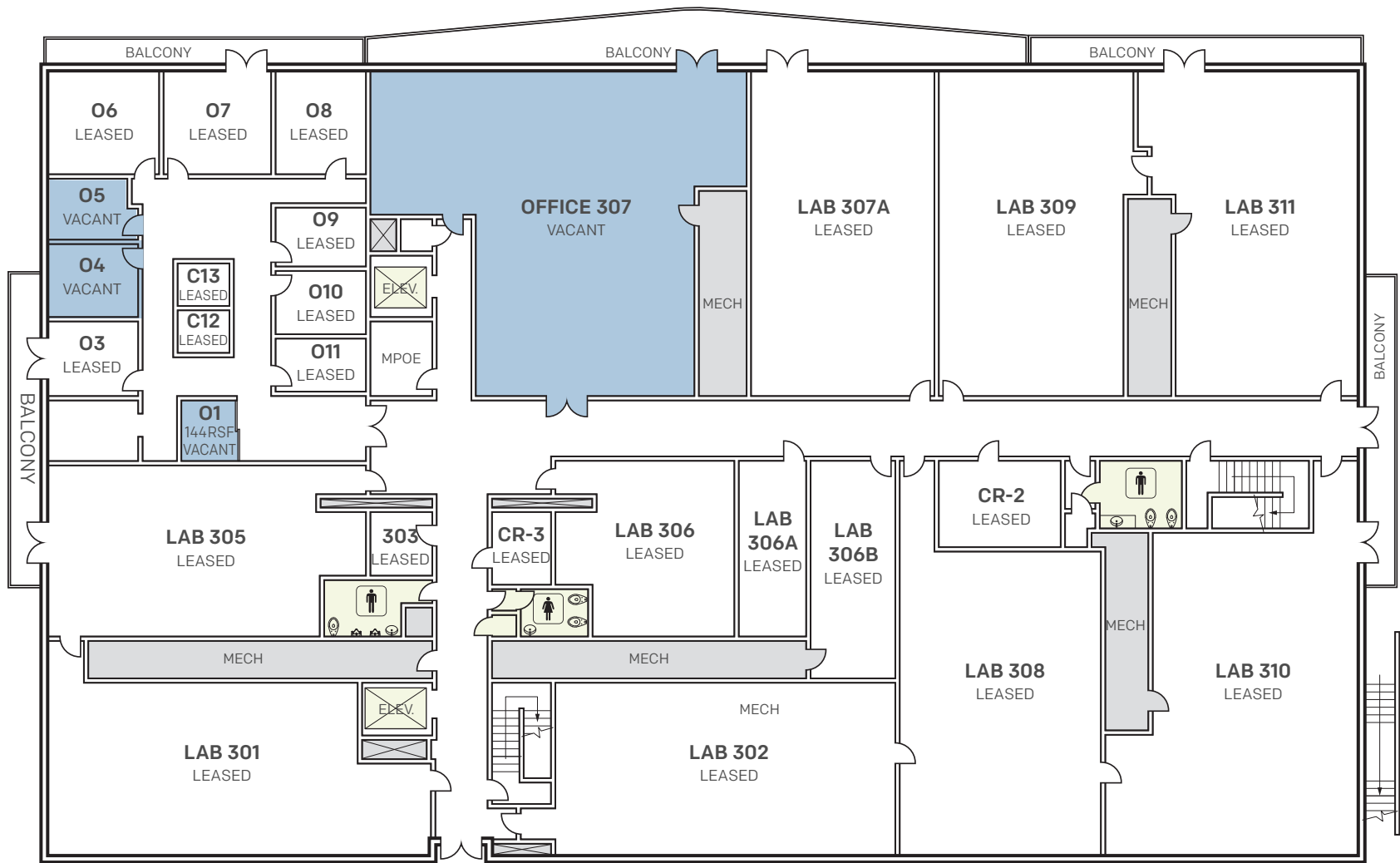

**CURRENT AVAILABILITIES**

SUITE	RSF	MO. RATE PSF	AVAILABLE
Office 300-01	144 SF	\$3.15/SF FSG	Now
Office 307	2,538 SF	Negotiable	Now
04	223 SF	Negotiable	Now
05	284 SF	Negotiable	Now

**FLOOR PLANS**

THIRD FLOOR

- VACANT SPACE
- BUILDING SERVICES
- BUILDING AMENITIES

NNN = \$1.05/SF

# FLOOR PLANS

## THIRD FLOOR

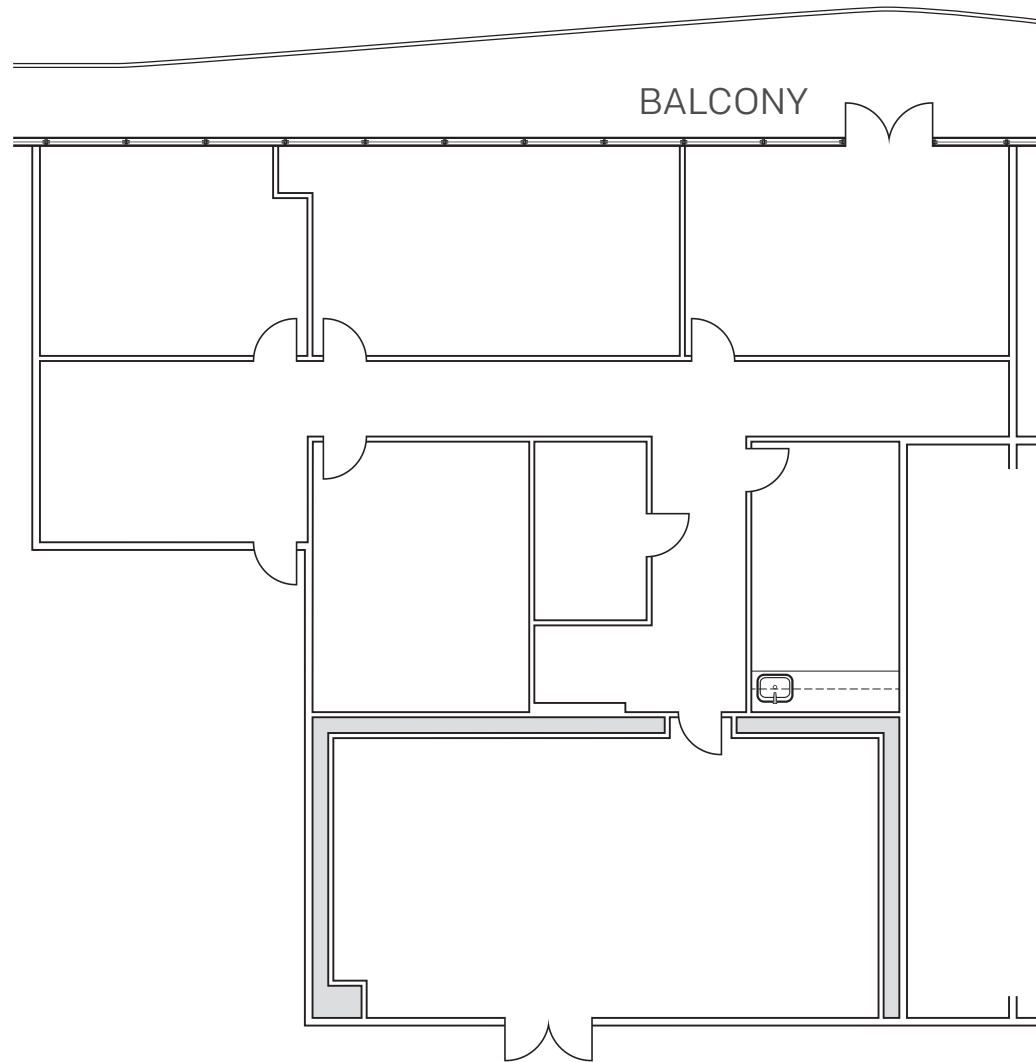
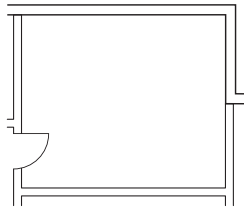

### SUITE 300-01

RSF	MO. RATE PSF	AVAILABLE
367 SF	\$3.15/SF FSG	Now

- Open Office Area

### SUITE 307

RSF	MO. RATE PSF	AVAILABLE
2,538 SF	Negotiable	Now

- Reception / Lobby
- (4) Offices
- Balcony Access
- Break Room
- Storage

# FLOOR PLANS

## THIRD FLOOR

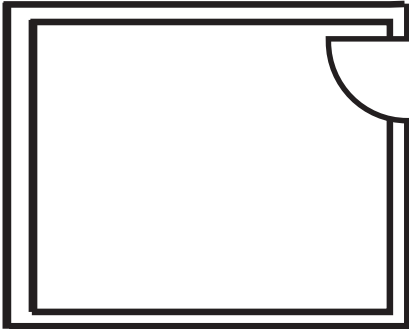

### SUITE 04

RSF	MO. RATE PSF	AVAILABLE
223 SF	Negotiable	Now

- Open Office Area



### SUITE 05

RSF	MO. RATE PSF	AVAILABLE
284 SF	Negotiable	Now

- Open Office Area

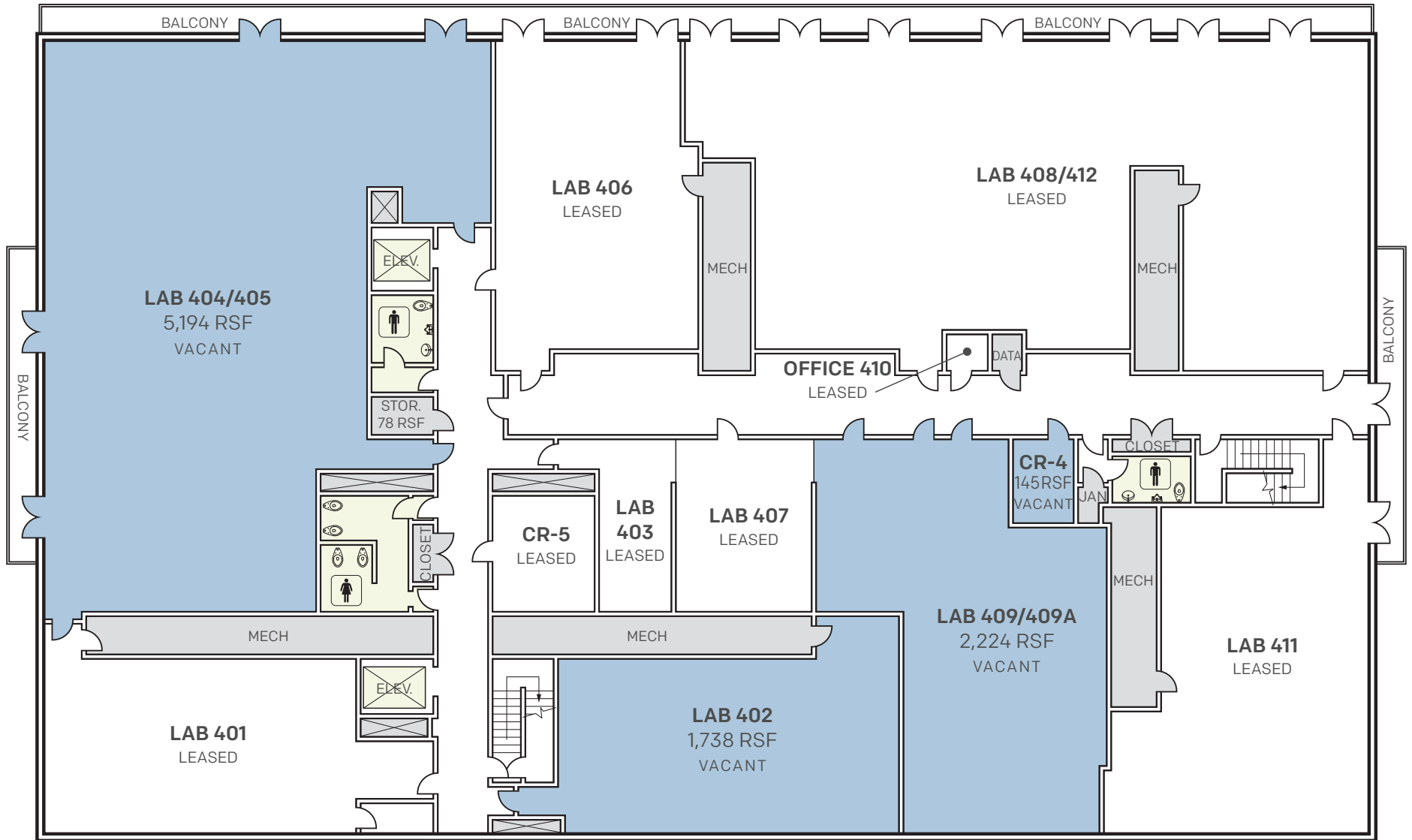

## FLOOR PLANS

### FOURTH FLOOR

VACANT SPACE

BUILDING SERVICES

BUILDING AMENITIES

## CURRENT AVAILABILITIES

SUITE	RSF	MO. RATE PSF	AVAILABLE
CR-4	145 SF	\$3.15/SF NNN	Now
Lab 402	1,738 SF	\$3.80/SF NNN	Now

SUITE	RSF	MO. RATE PSF	AVAILABLE
Lab 404/405	5,194 SF	\$4.75/SF NNN	30-Days
Lab 409/409A	2,244 SF	\$4.25/SF NNN	Now

NNN = \$1.05/SF

# FLOOR PLANS

## FOURTH FLOOR

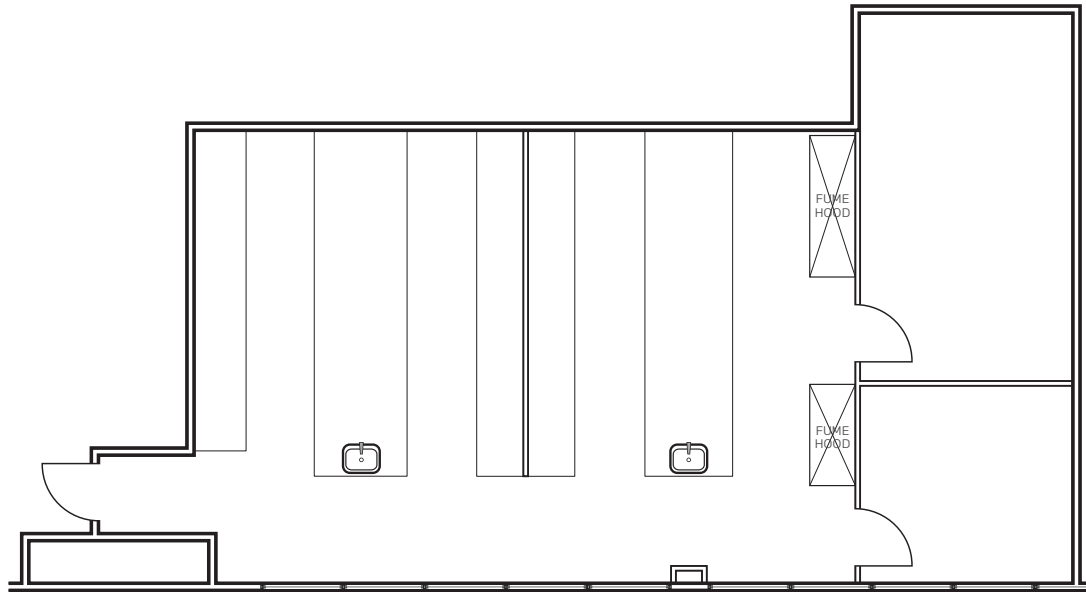
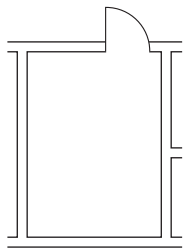

### SUITE CR-4

RSF	MO. RATE PSF	AVAILABLE
145 SF	\$3.15/SF NNN	Now

- Open Cold Room / Storage

### SUITE 402

RSF	MO. RATE PSF	AVAILABLE
1,738 SF	\$3.80/SF NNN	Now

- Open Lab Space
- (2) Fume Hoods
- (2) Offices
- (2) Sinks

# FLOOR PLANS

## FOURTH FLOOR

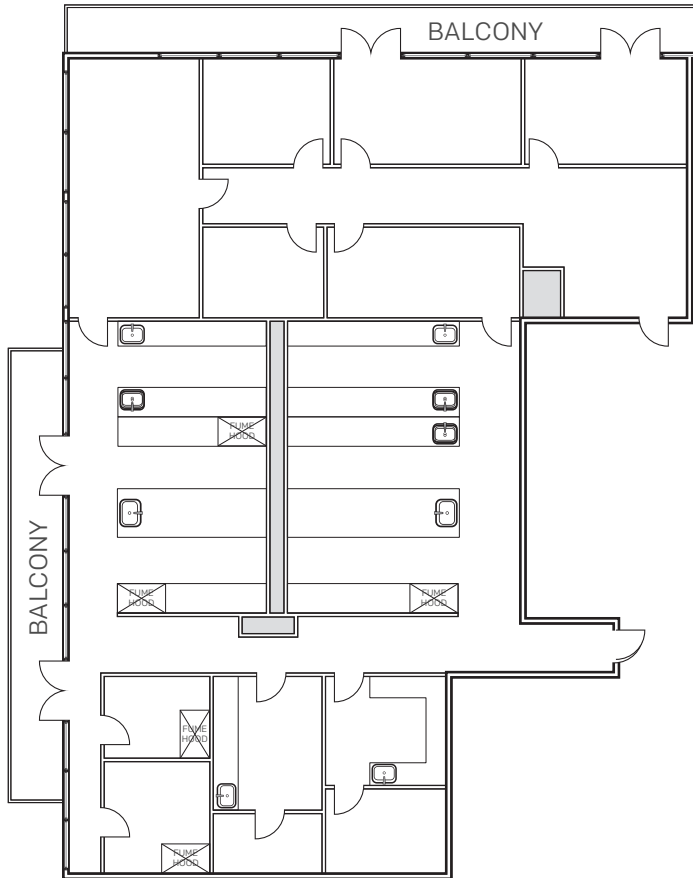

### SUITE 404/405

RSF	MO. RATE PSF	AVAILABLE
5,194 SF	\$4.75/SF NNN	Now

- Open Lab Area
- (1) Conference Room
- Break Area
- Balcony Access
- Storage
- (9) Offices
- (5) Fume Hoods
- (9) Sinks

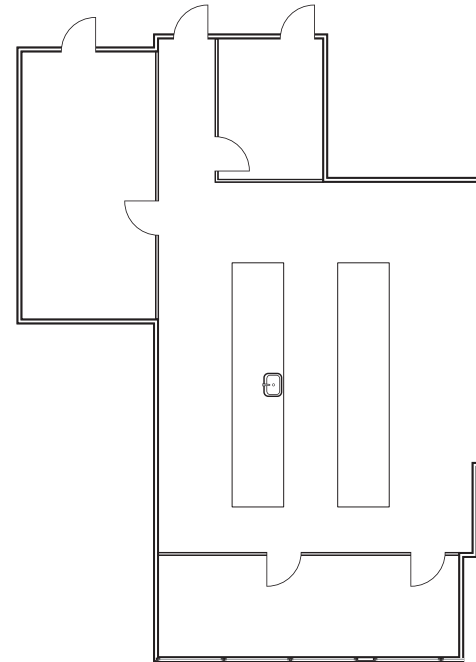

### SUITE 409/409A

RSF	MO. RATE PSF	AVAILABLE
2,244 SF	\$4.25/SF NNN	Now

- Open Lab Space
- (1) Sink
- (3) Offices

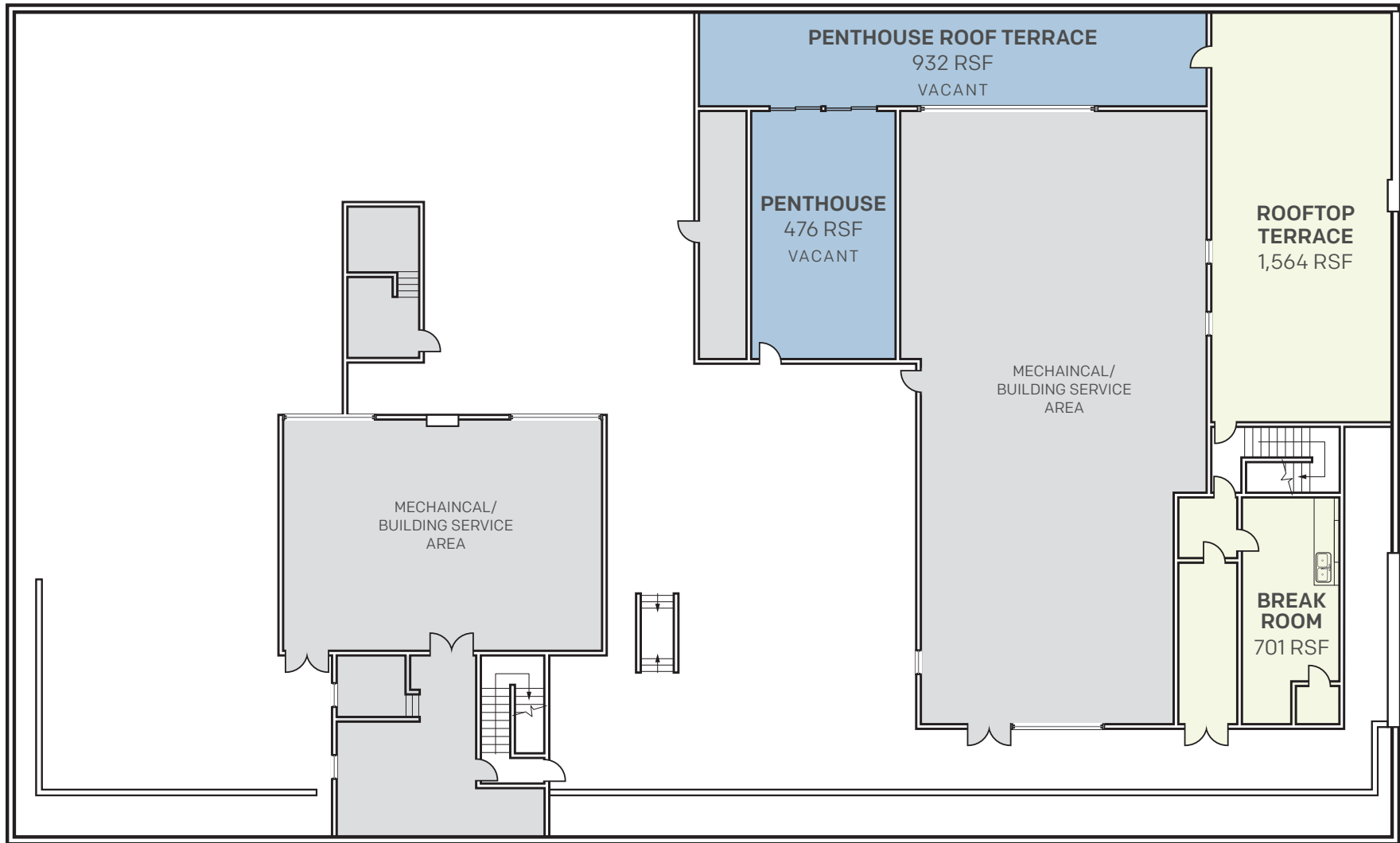

## FLOOR PLANS

### FIFTH FLOOR

VACANT SPACE

BUILDING SERVICES

BUILDING AMENITIES

## CURRENT AVAILABILITIES

SUITE	RSF	MO. RATE PSF	AVAILABLE
Penthouse	1,408 SF	Negotiable	90-Days

# FLOOR PLANS

## FIFTH FLOOR

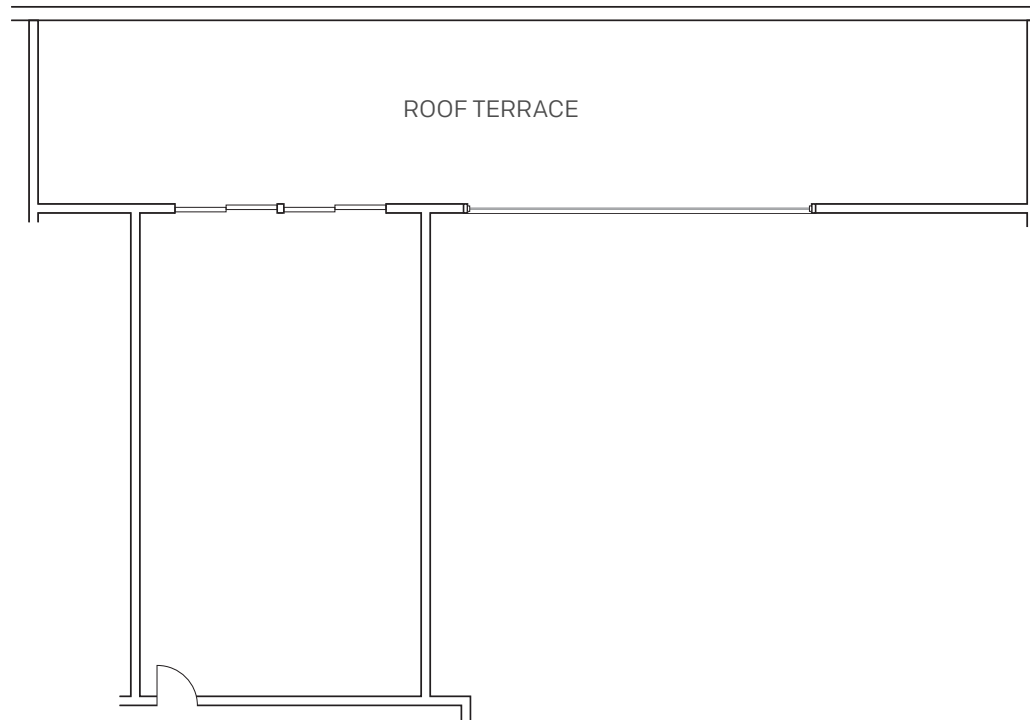

### SUITE 404/405

RSF	MO. RATE PSF	AVAILABLE
5,194 SF	\$4.75/SF FSG	Now

---

- Open Office Area
- Shell Condition
- Roof Terrace

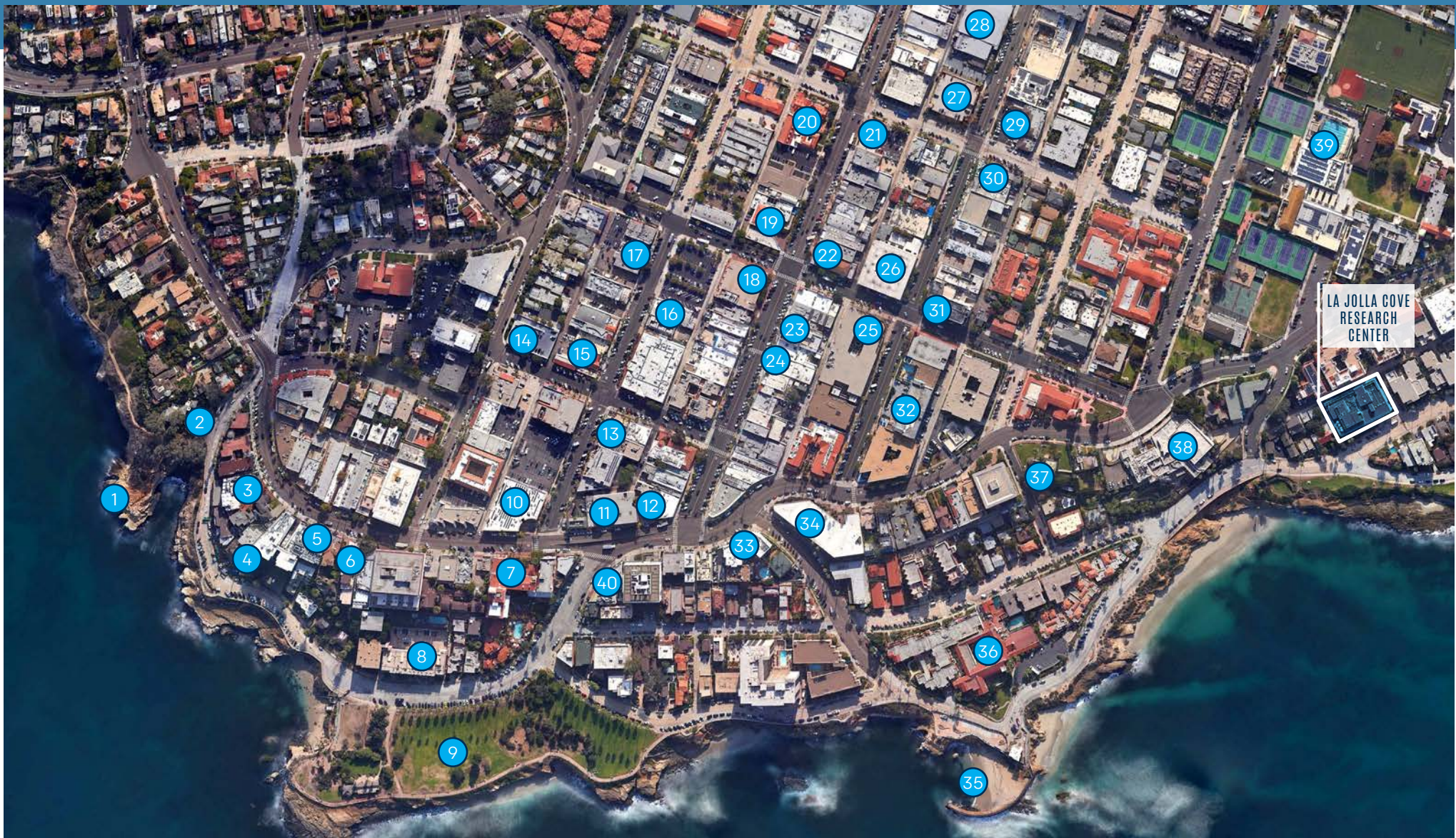

- 1. LA JOLLA UNDERWATER PARK
- 2. SUNNY JIM'S SEA CAVE
- 3. EDDIE V'S
- 4. BROCKTON VILLA
- 5. GEORGE'S AT THE COVE
- 6. DUKE'S LA JOLLA
- 7. LA VALENCIA HOTEL
- 8. LA JOLLA COVE HOTEL & SUITES
- 9. LA JOLLA COVE
- 10. MORGAN STANLEY

- 11. CODY'S LA JOLLA
- 12. THE SPOT
- 13. PUESTO LA JOLLA
- 14. SUSHI NEKOSAN
- 15. BURGER LOUNGE
- 16. CUCINA MIGRANTE
- 17. HENNESSEY'S TAVERN
- 18. UNION BANK
- 19. CHASE BANK
- 20. MARY STAR OF THE SEA

- 21. WELLS FARGO BANK
- 22. ADELAIDE'S LA JOLLA
- 23. WARWICK'S
- 24. RALPH LAUREN
- 25. PROSPECT HOME FINANCE
- 26. CHARLES SCHWAB
- 27. BANK OF AMERICA
- 28. THE LOT LA JOLLA
- 29. SUGAR & SCRIBE BAKERY
- 30. THE COTTEAGE LA JOLLA

- 31. THE EMPRESS HOTEL
- 32. INN BY THE SEA LA JOLLA
- 33. GRANDE COLONIAL HOTEL
- 34. WELL'S FARGO ADVISORS
- 35. CHILDREN'S POOL LA JOLLA
- 36. CASA DE MAÑANA RETIREMENT
- 37. LA JOLLA HISTORICAL SOCIETY
- 38. MUSEUM OF CONTEMPORARY ART
- 39. THE BISHOP'S SCHOOL
- 40. CRAB CITY



La Jolla ranked **NO. 196 CITY** in **CALIFORNIA** of 1,762  
with a livability ranking of **7** within **SAN DIEGO**.



LA JOLLA FOUNDED  
**1887**

COUNTY OF  
**SAN DIEGO**

COASTAL  
**REGION**

#1 EMPLOYER  
AMERICAN  
SYSTEMS

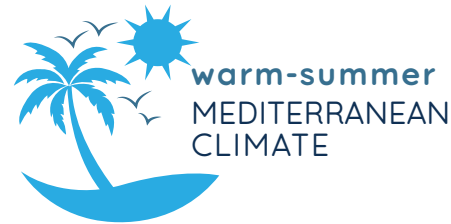

THE LARGEST INSTITUTION  
IN LA JOLLA IS **UC SAN DIEGO**,  
WITH **11,300 GRADUATES**

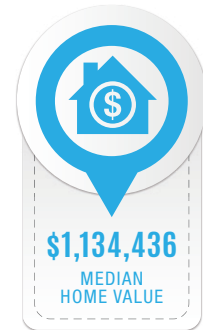
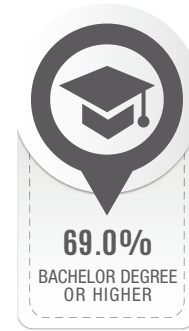

**LA JOLLA'S** daily  
average traffic count for a  
**2 MILE RADIUS**

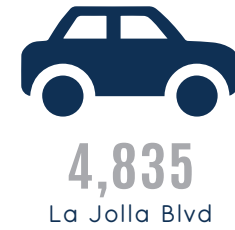

**CHRIS DURBIN**

Associate | Lic.# 02227661  
858.458.3339 | cdurbin@voitco.com

**MILES ARNOLD**

Senior Associate | Lic.#02094013  
858.458.3324 | marnold@voitco.com

**Voit**  
REAL ESTATE SERVICES

4180 La Jolla Village Drive, Suite 100, La Jolla, CA 92037 | 858.453.0505 P | 858.408.3976 F | Lic.#01991785 | www.voitco.com

Licensed as Real Estate Salespersons by the DRE. ©2026 Voit Real Estate Services, Inc. All Rights Reserved. The information contained herein has been obtained from sources we deem reliable. While we have no reason to doubt its accuracy, we do not guarantee it.